

SERIE S30

S30 è il nuovissimo profilo della gamma **SESAMO**, ideale per l'installazione di porte scorrevoli per ogni tipo di utilizzo e condizione.

Realizzato per garantire le migliori performance in termini di robustezza, leggerezza e versatilità, la serie **S30** risulta un perfetto complemento per la realizzazione di ingressi automatici.



Il profilo risulta facile da lavorare e assemblare grazie al numero ridotto di componenti, può essere utilizzato con diversi tipi di vetro, siano essi temperati, stratificati o camera, spessore massimo 25mm.

INDICE

Sezione A	Articoli in vendita
Sezione B	Sezioni profili Scala 1:1
Sezione C	Sezioni orizzontali Scala 1:1
Sezione D	Sezioni Verticali Scala 1:1
Sezione E	Vetrazioni Scala 1:1
Sezione F	Casi standard
Sezione G	Tavole di assemaggio
Sezione H	Tavole di lavorazione

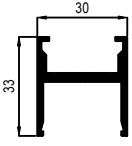
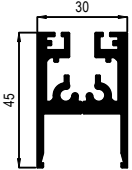
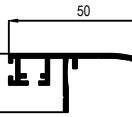
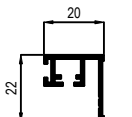
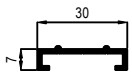
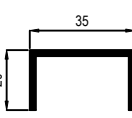
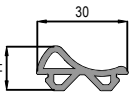
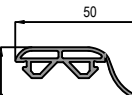
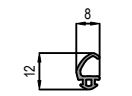
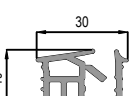
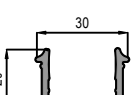

MATRICE	SEZIONE	CODICE IN VENDITA		DESCRIZIONE	PESO	L BARRE	CONFEZIONE
PF32.1		PF32.10	GREZZO	MONTANTE	0,597 Kg/m	5,1m	N.6 BARRE
		PF32.11	OSSIDATO				
		PF32.12	RAL				
PF32.2		PF32.20	GREZZO	TRAVERSO	1,235 Kg/m	5,1m	N.3 BARRE
		PF32.21	OSSIDATO				
		PF32.22	RAL				
PF32.3		PF32.30	GREZZO	LABIRINTO	0,385 Kg/m	5,1m	N.10 BARRE
		PF32.31	OSSIDATO				
		PF32.32	RAL				
PF32.4		PF32.40	GREZZO	CORNICE	0,241 Kg/m	5,1m	N.14 BARRE
		PF32.41	OSSIDATO				
		PF32.42	RAL				
PF32.5		PF32.50	GREZZO	SOTTO TRAVERSO	0,193 Kg/m	5,1m	N.14 BARRE
		PF32.51	OSSIDATO				
		PF32.52	RAL				
PF32.6		PF32.60	GREZZO	PROFILO AD "U"	0,383 Kg/m	6,5m	N.8 BARRE
		PF32.61	OSSIDATO				
		PF32.62	RAL				
-		PF32.81	EPDM NERO	GUARNIZIONE DI BATTUTA	0,145 Kg/m	-	ROTOLO DA 30m
-		PF32.82	EPDM NERO	GUARNIZIONE LABIRINTO	0,193 Kg/m	-	ROTOLO DA 30m
-		PF32.83	EPDM NERO	GUARNIZIONE TENUTA INTERNA	0,039 Kg/m	-	ROTOLO DA 30m
-		PF32.84	EPDM NERO	GUARNIZIONE VETRI STRATIFICATI	0,212 Kg/m	-	ROTOLO DA 30m
-		PF32.85	EPDM NERO	GUARNIZIONE VETRI CAMERA	0,114 Kg/m	-	ROTOLO DA 30m

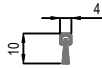
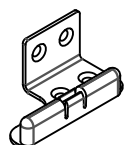
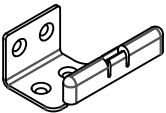
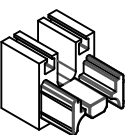
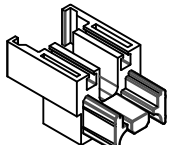
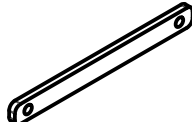
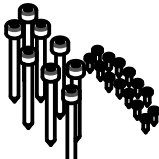
MATRICE	SEZIONE	CODICE IN VENDITA	DESCRIZIONE	PESO	L BARRE	CONFEZIONE
-		PF32.86	SPAZZOLINO MORBIDO H 6mm	-	-	ROTOLO DA 500m
-		PF32.87	SPAZZOLINO MORBIDO H 11mm	-	-	ROTOLO DA 500m
-		PF32.88	SPAZZOLINO RIGIDO H 10mm	-	2,5m	N.50 BARRE
-		PF32.89	PATTINO ANTA SCORREVOLE DESTRA	-	-	CONFEZIONE N.10 PEZZI
-		PF32.90	PATTINO ANTA SCORREVOLE SINISTRA	-	-	CONFEZIONE N.10 PEZZI
-		PF32.91	SQUADRETTA DI ALLINEAMENTO INTERNA	-	-	CONFEZIONE N.12 PEZZI
-		PF32.92	SQUADRETTA DI ALLINEAMENTO ESTERNA	-	-	CONFEZIONE N.12 PEZZI
-		PF32.93	KIT FISSAGGIO CARRELLI	-	-	CONFEZIONE N.10 PEZZI
-		PF32.94	KIT VITI FISSAGGIO ANTA	-	-	CONFEZIONE N.15 PEZZI

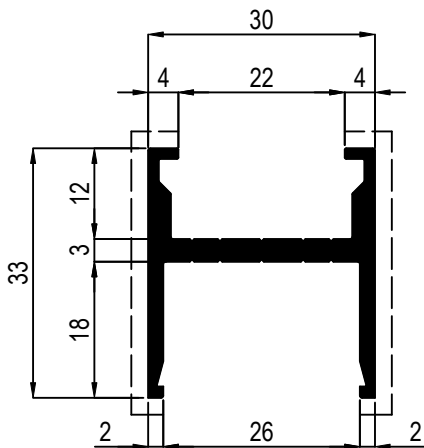

PF32.1

P: 0,597 Kg/m
L: 5,1m
Sup.: 78mm
Perimetro: 356,72mm

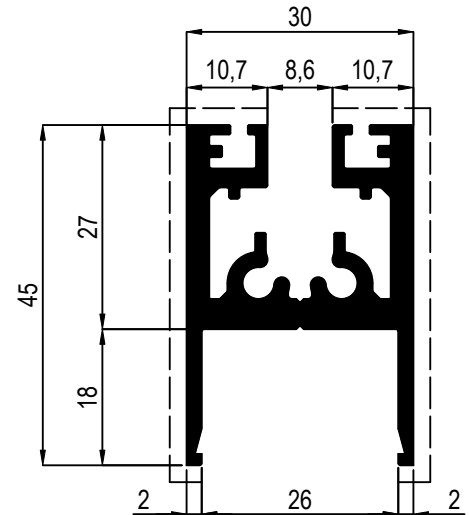

PF32.2

P: 1,235 Kg/m
L: 5,1m
Sup.: 116mm
Perimetro: 197,47mm

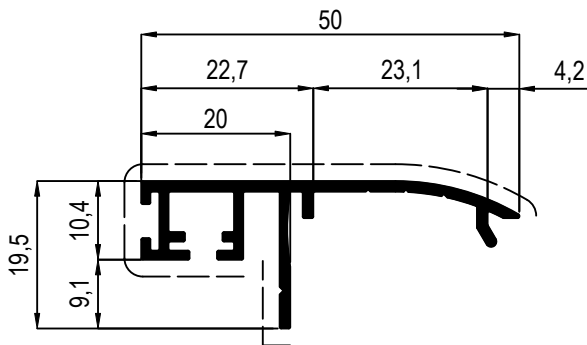

PF32.3

P: 0,385 Kg/m
L: 5,1m
Sup.: 84mm
Perimetro: 219,32mm

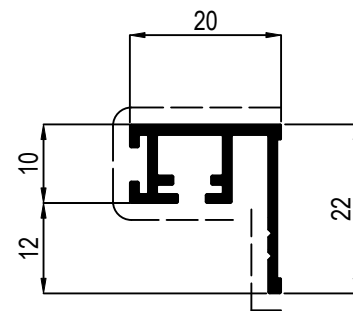

PF32.4

P: 0,241 Kg/m
L: 5,1m
Sup.: 69mm
Perimetro: 148,20mm

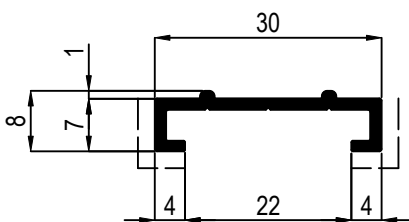

PF32.5

P: 0,193 Kg/m
L: 5,1m
Sup.: 22mm
Perimetro: 97,08mm

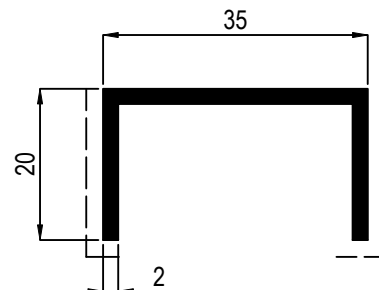

PF32.6

P: 0,383 Kg/m
L: 6,5m
Sup.: 44mm
Perimetro: 146mm

A NODO DI CODA SCALA 1:1
ANTA FISSA

SEZIONE CON VETRO STRATIFICATO
PER ULTERIORI VETRI VEDI CAPITOLO
VETRAZIONE

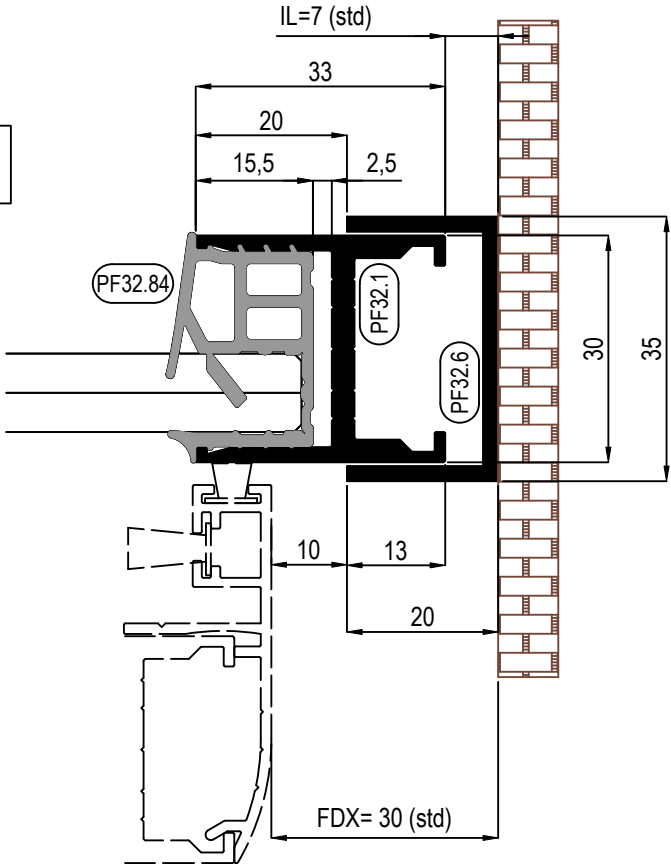

B NODO DI CODA SCALA 1:1
ANTA SCORREVOLE

SEZIONE CON VETRO STRATIFICATO
PER ULTERIORI VETRI VEDI CAPITOLO
VETRAZIONE

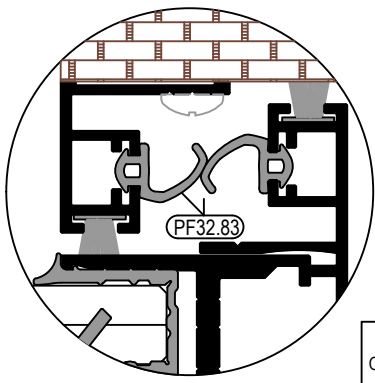
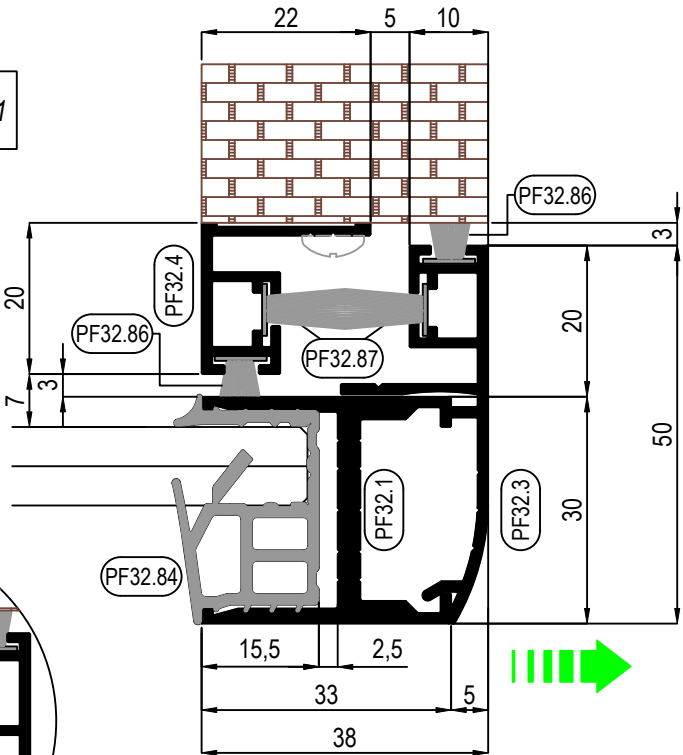

OPZIONE CON GUARNIZIONE DI TENUTA

C NODO DI CODA SCALA 1:1

ANTA SCORREVOLE
SOLUZIONE OPZIONALE

SEZIONE CON VETRO STRATIFICATO
PER ULTERIORI VETRI VEDI CAPITOLO
VETRAZIONE

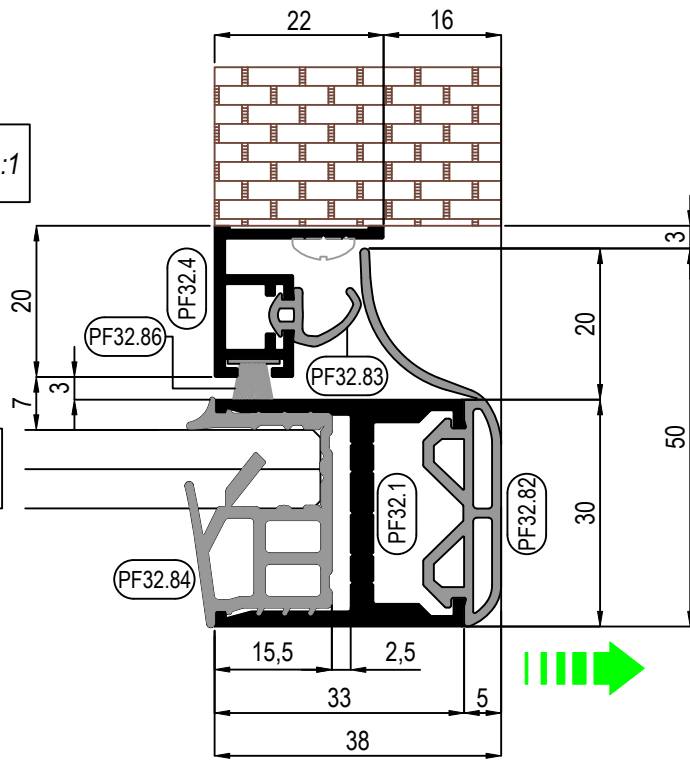

D LABIRINTO SCALA 1:1

ANTA FISSA + ANTA SCORREVOLE

SEZIONE CON VETRO STRATIFICATO
PER ULTERIORI VETRI VEDI CAPITOLO
VETRAZIONE

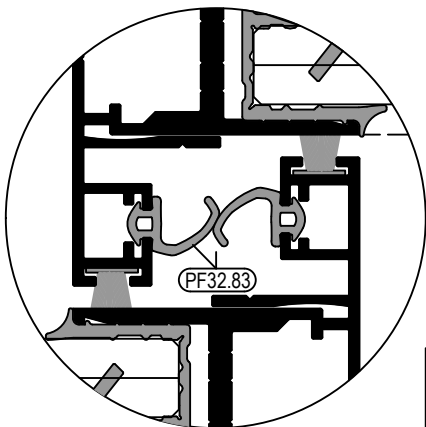
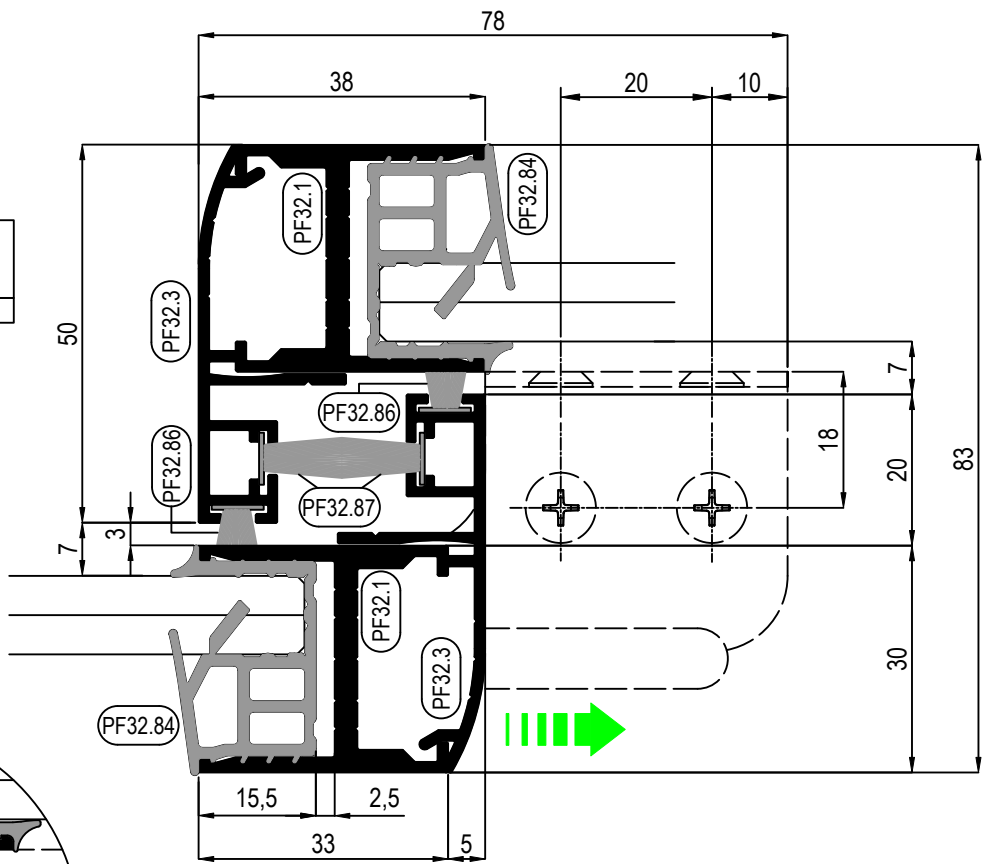

OPZIONE CON GUARNIZIONE DI TENUTA

E LABIRINTO SCALA 1:1
 ANTA FISSA + ANTA SCORREVOLE
 SOLUZIONE OPZIONALE

SEZIONE CON VETRO STRATIFICATO
 PER ULTERIORI VETRI VEDI CAPITOLO
 VETRAZIONE

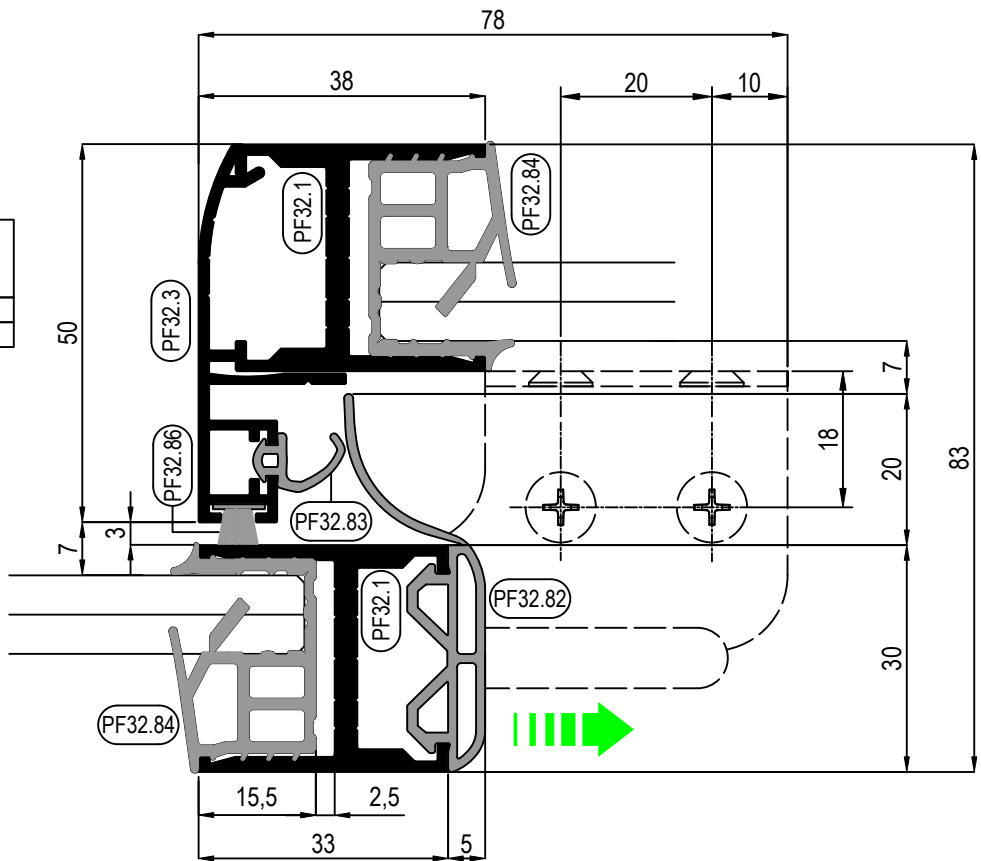

E NODO BATTUTA SCALA 1:1
 ANTA SCORREVOLE

SEZIONE CON VETRO STRATIFICATO
 PER ULTERIORI VETRI VEDI CAPITOLO
 VETRAZIONE

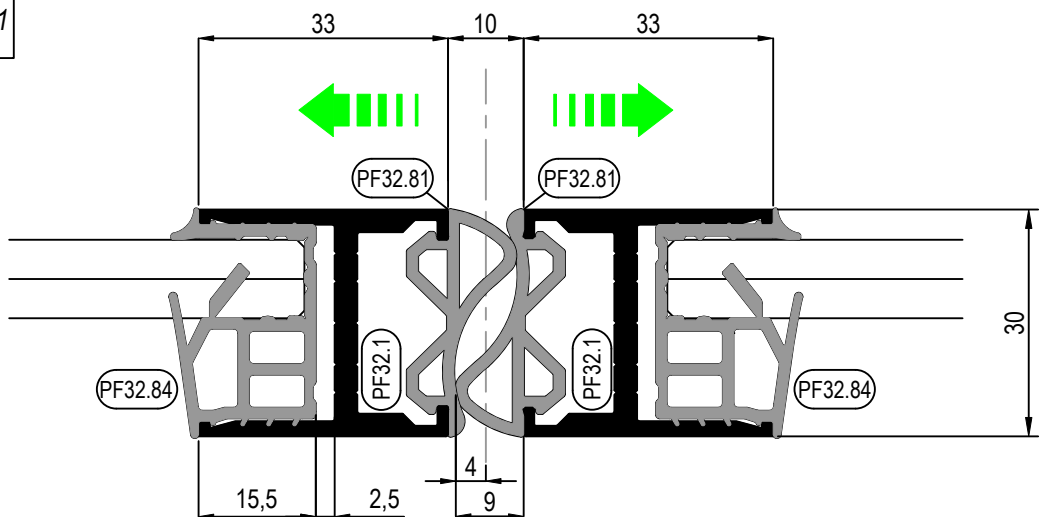

F NODO BATTUTA SCALA 1:1

ANTA SCORREVOLE

SEZIONE CON VETRO STRATIFICATO
PER ULTERIORI VETRI VEDI CAPITOLO
VETRAZIONE

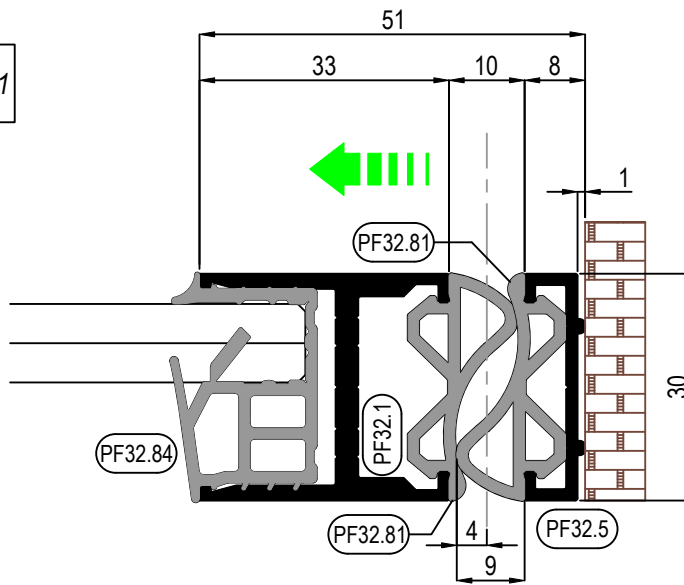

G NODO SUPERIORE SCALA 1:1

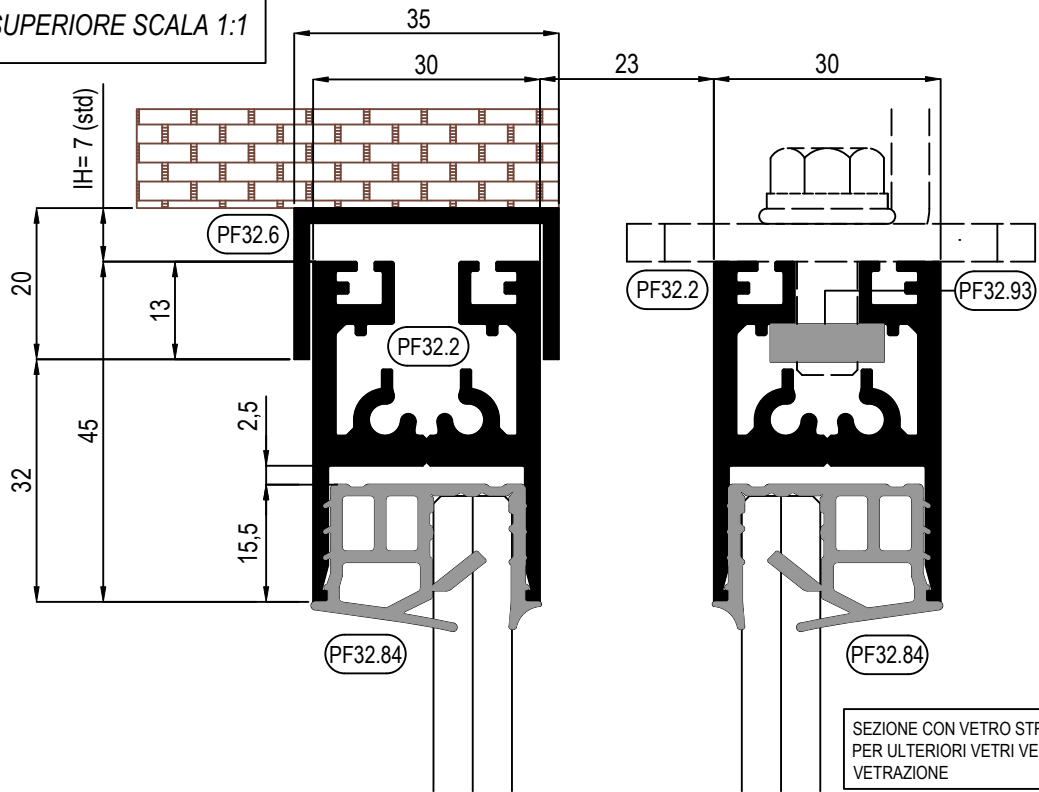

SEZIONE CON VETRO STRATIFICATO
PER ULTERIORI VETRI VEDI CAPITOLO
VETRAZIONE

H NODO SUPERIORE VANO PASSAGGIO SCALA 1:1

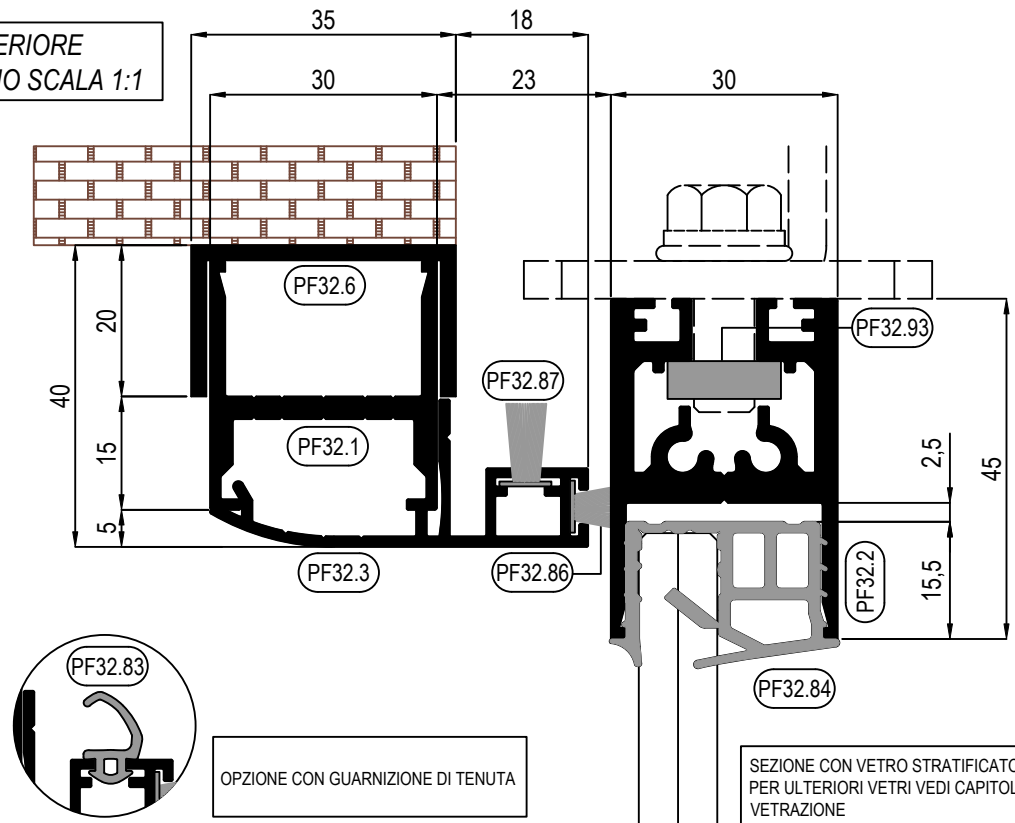

OPZIONE CON GUARNIZIONE DI TENUTA

SEZIONE CON VETRO STRATIFICATO
PER ULTERIORI VETRI VEDI CAPITOLO
VETRAZIONE

I NODO SUPERIORE SCALA 1:1

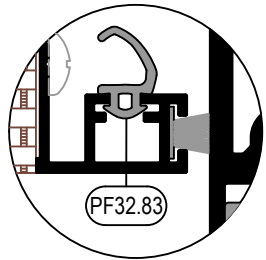

OPZIONE CON GUARNIZIONE DI TENUTA

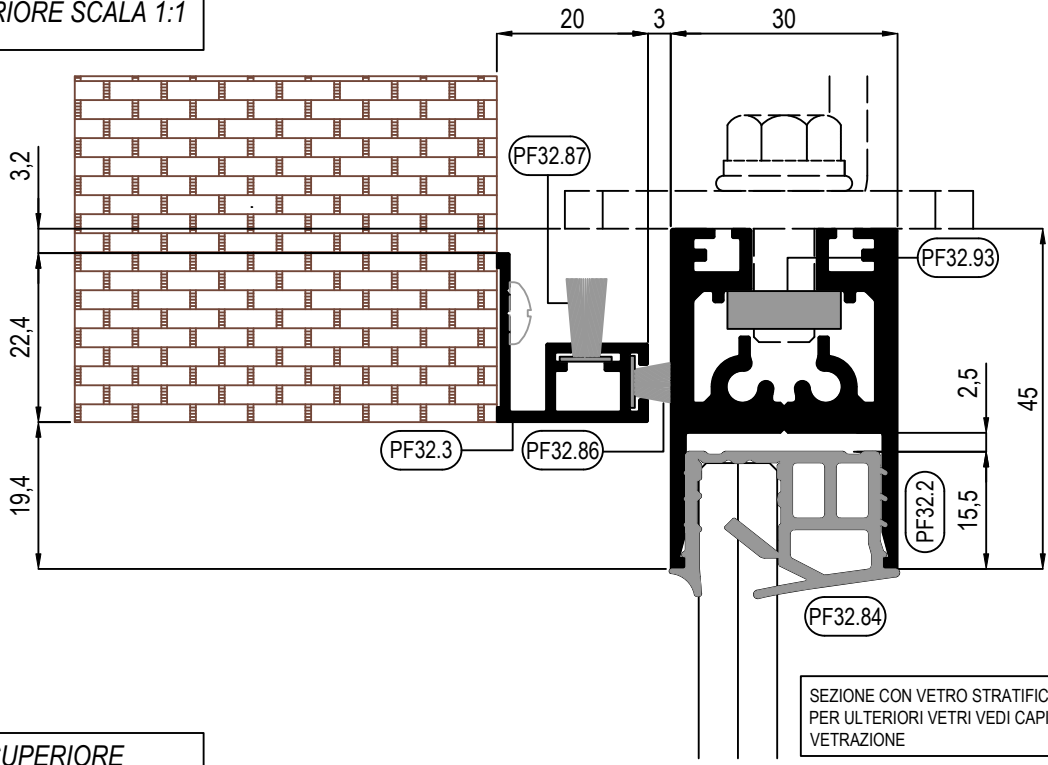

SEZIONE CON VETRO STRATIFICATO PER ULTERIORI VETRI VEDI CAPITOLO VETRAZIONE

L NODO SUPERIORE TELESCOPICA SCALA 1:1

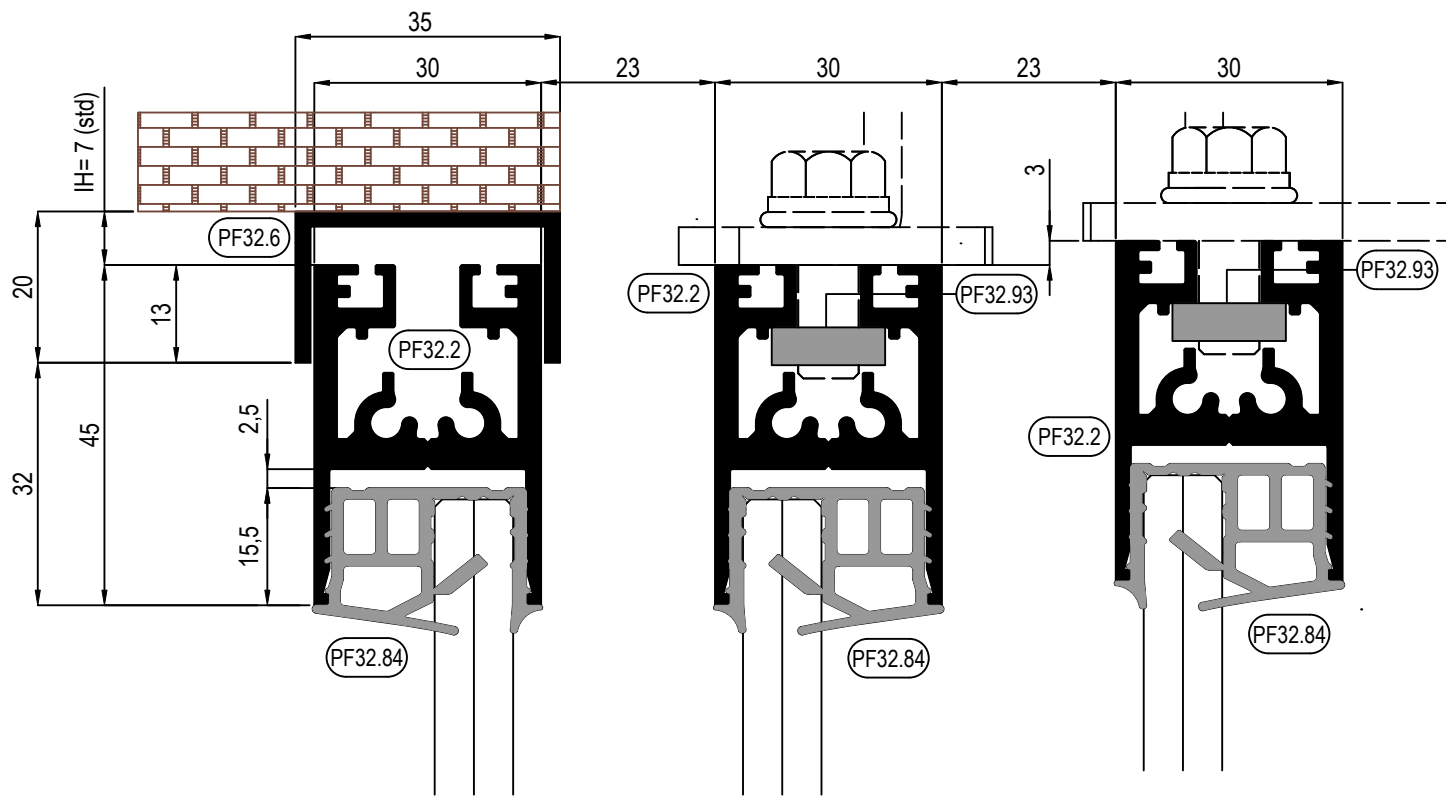

SEZIONE CON VETRO STRATIFICATO PER ULTERIORI VETRI VEDI CAPITOLO VETRAZIONE



M NODO SUPERIORE TELESCOPICA SCALA 1:1

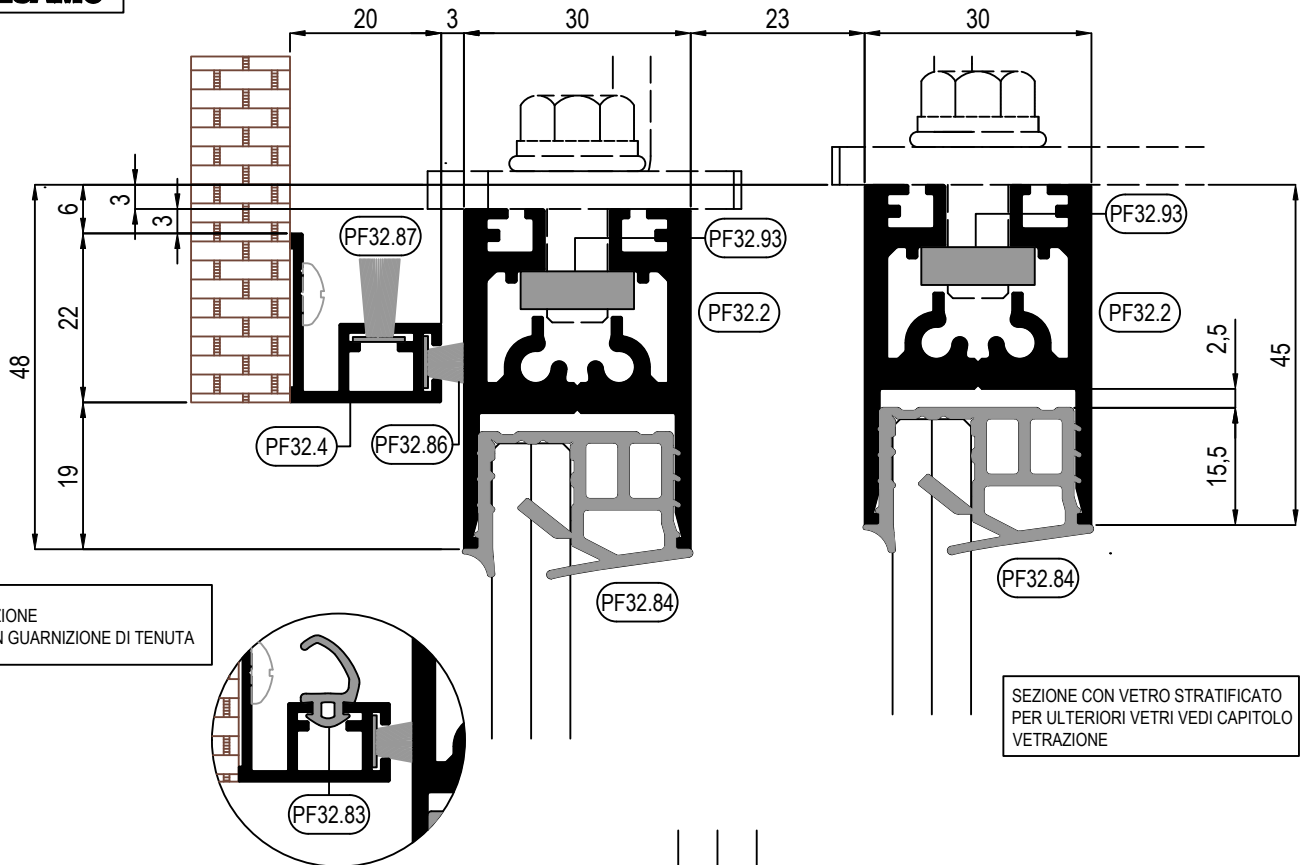

N NODO DIVISIONE SPECCHIATURA ANTA SCALA 1:1

LAV. M30-08

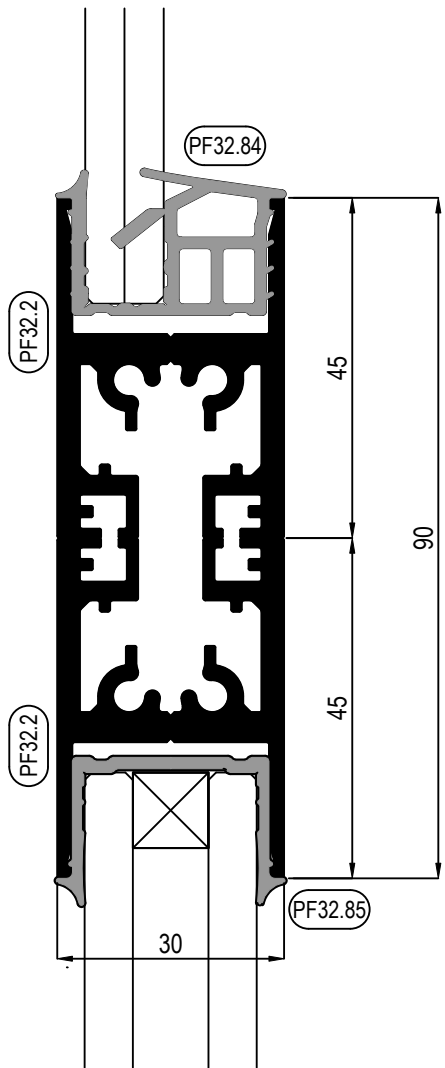

O NODO INFERIORE SCALA 1:1

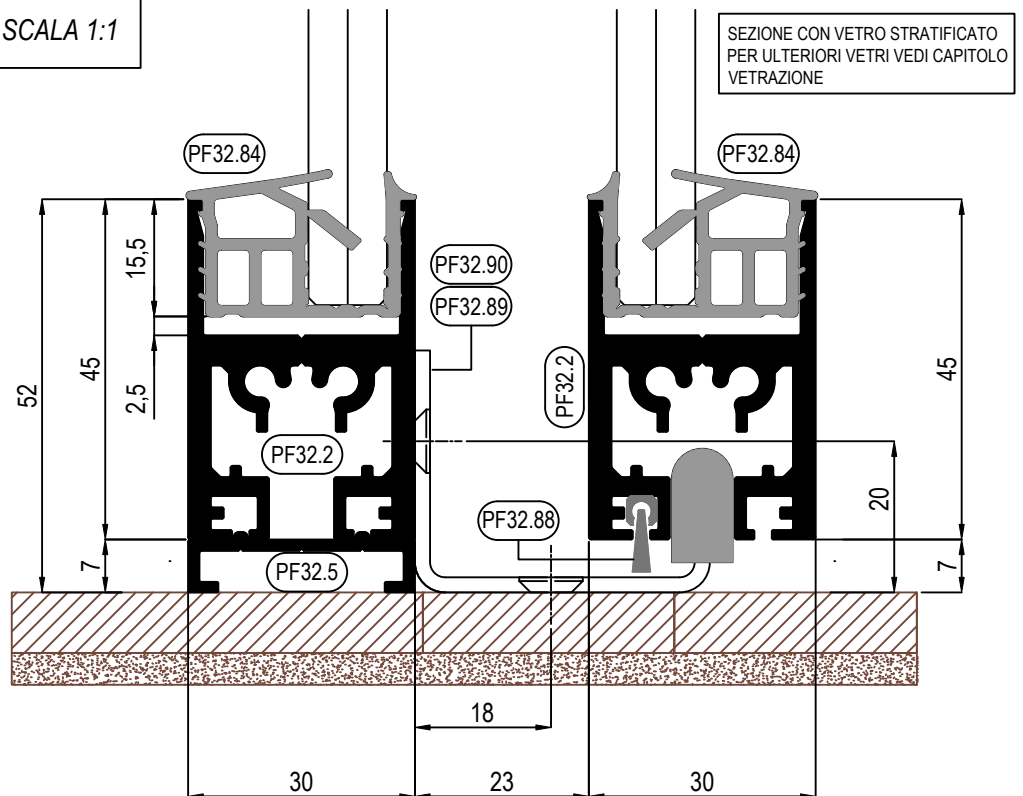

P NODO INFERIORE SCALA 1:1

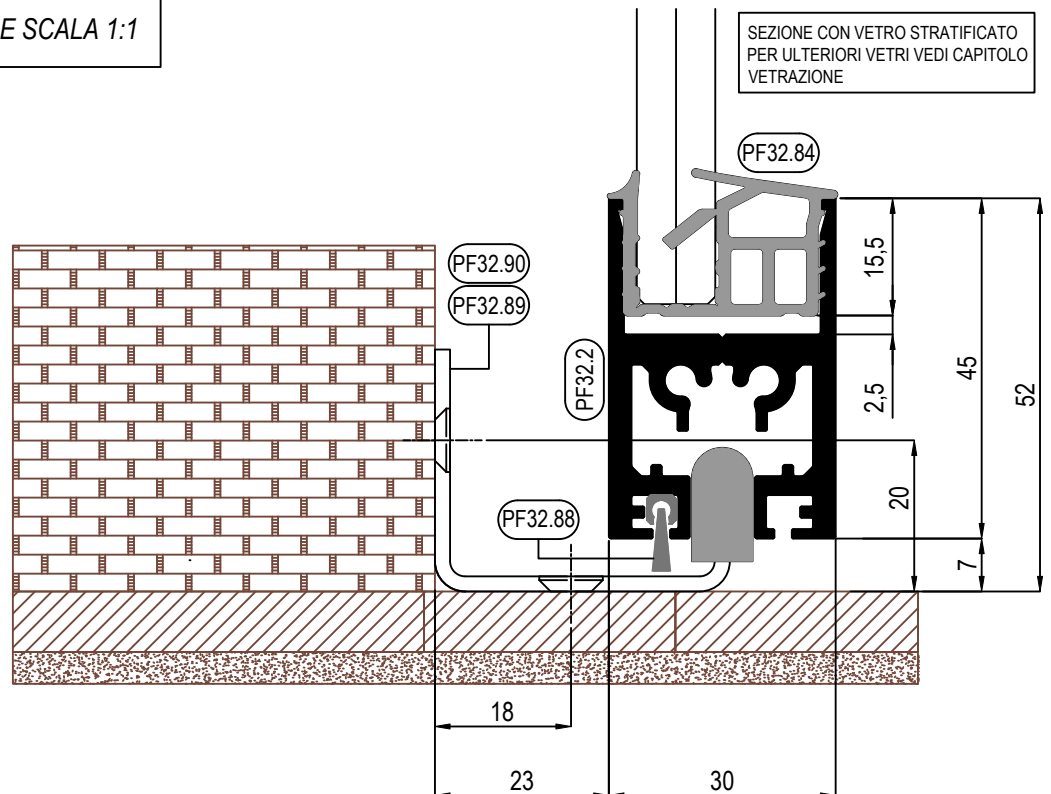

Q NODO INFERIORE
TELESCOPICA SCALA 1:1

NODI SEZ. VERTICALE SCALA 1:1

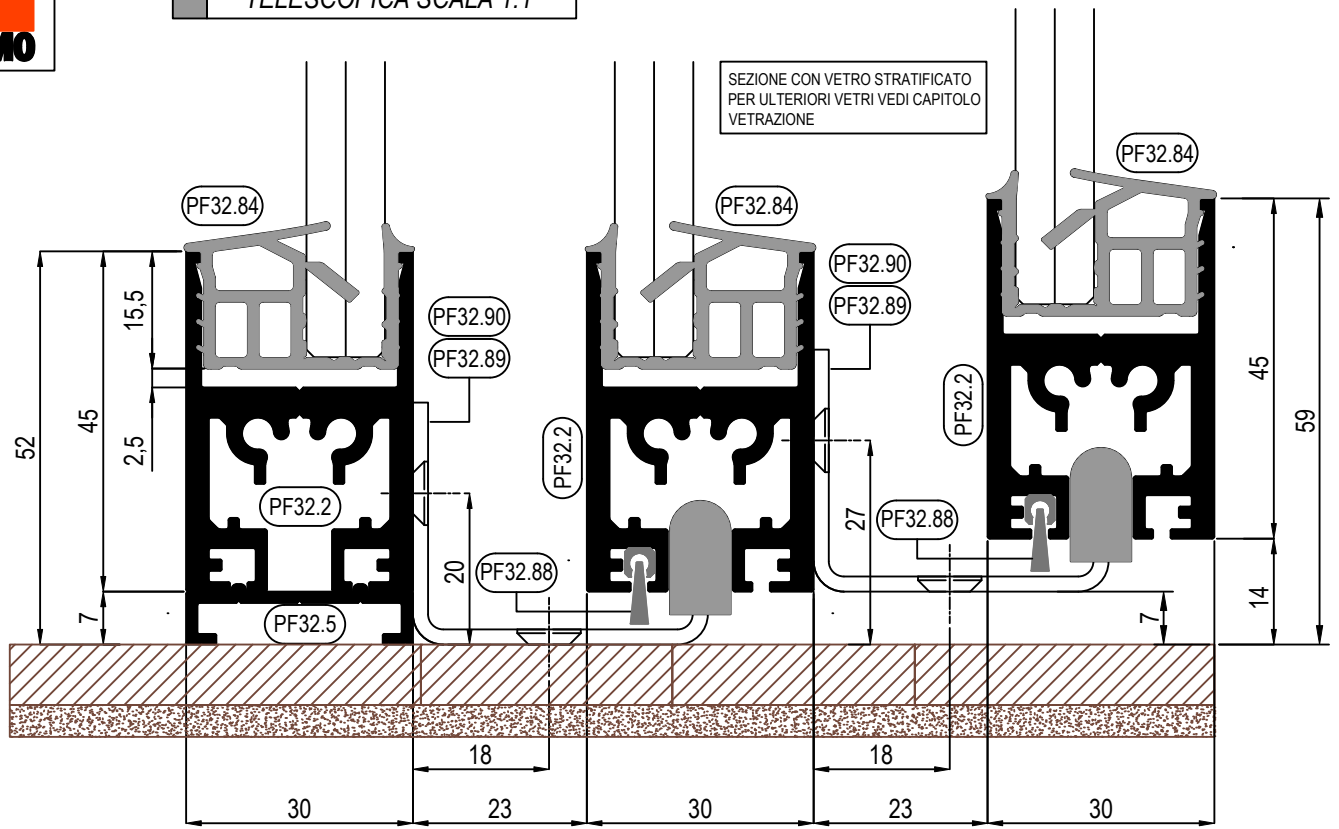

R NODO INFERIORE
TELESCOPICA SCALA 1:1

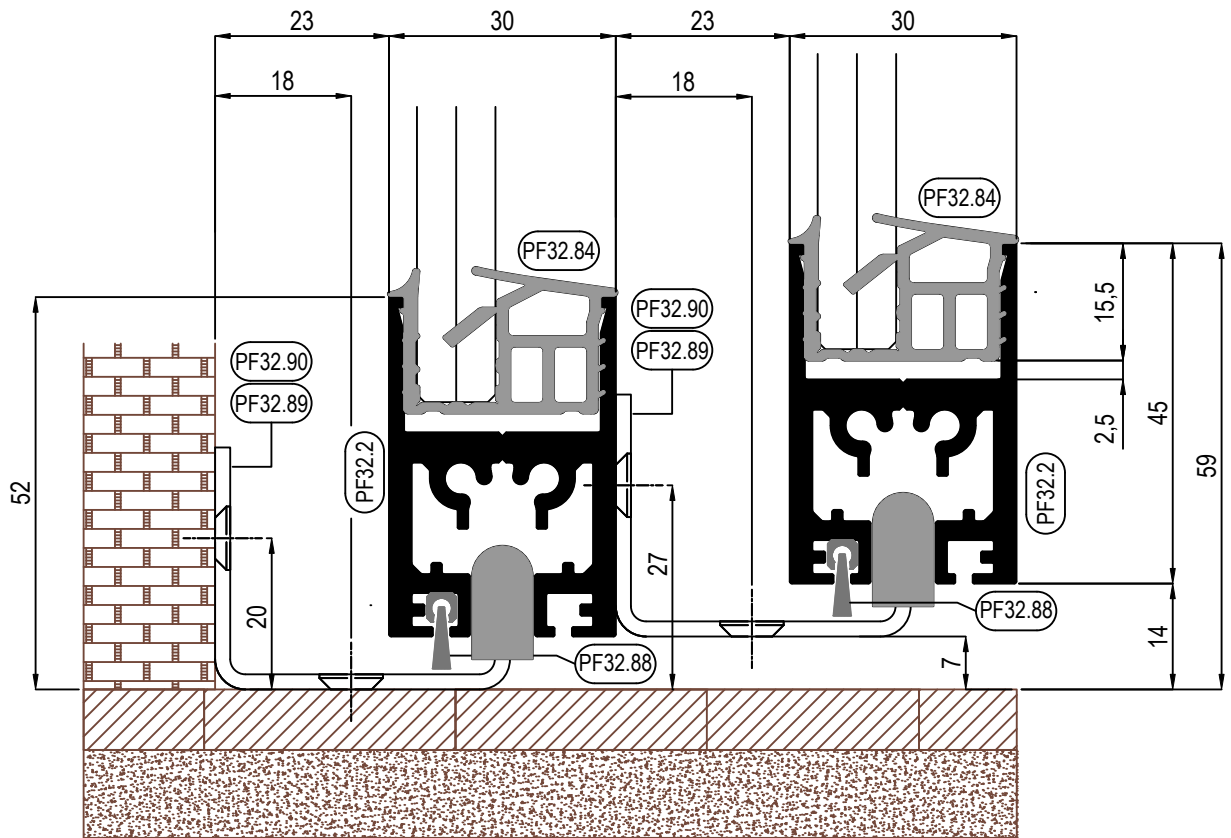

A STRATIFICATO 44.1

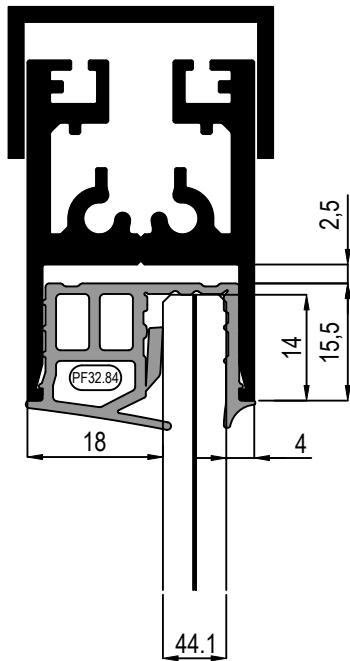

B STRATIFICATO 44.2

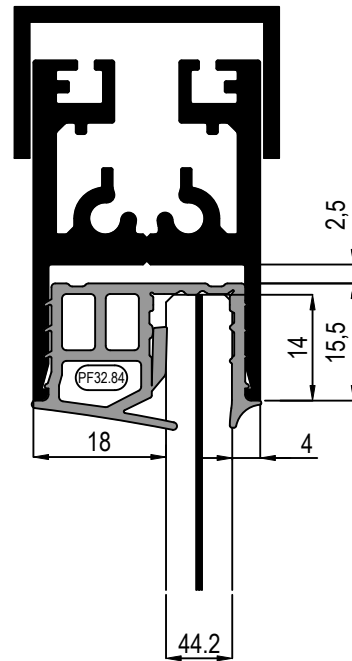

C STRATIFICATO 55.1

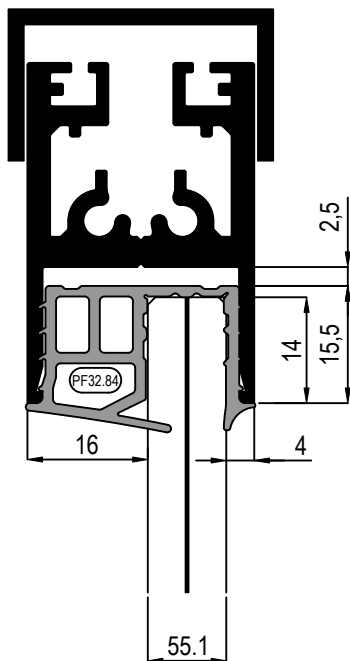

D STRATIFICATO 55.2

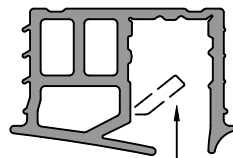
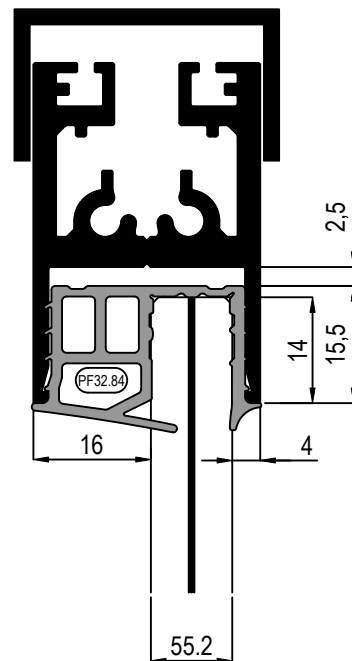

STRAPPARE LABBRO

E CAMERA 23mm

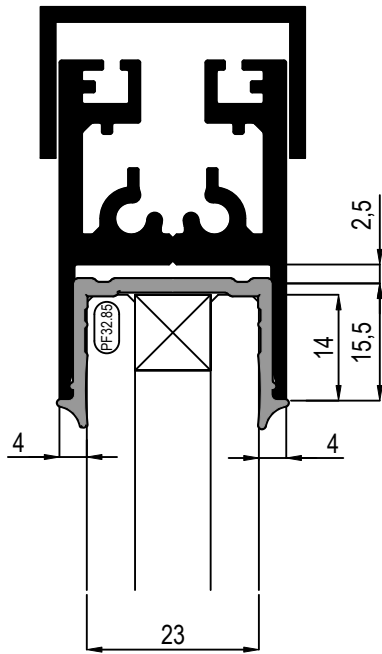

F CAMERA 24mm

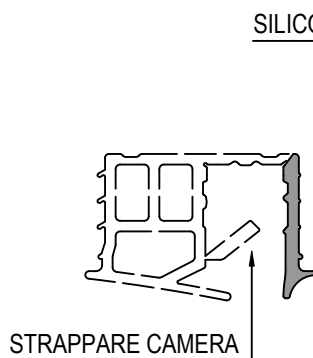
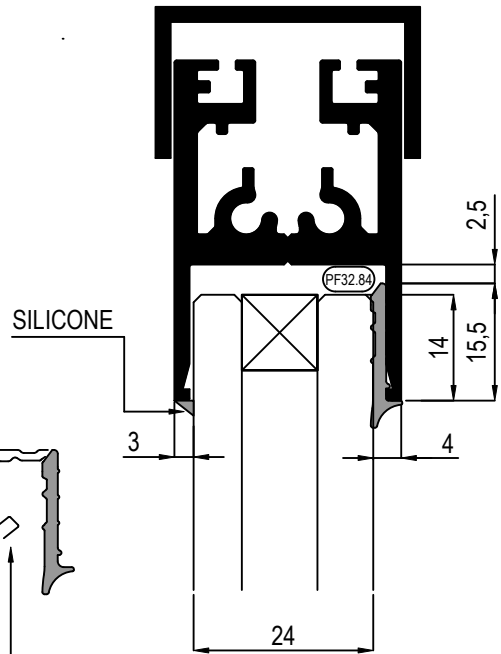

G CAMERA 25mm

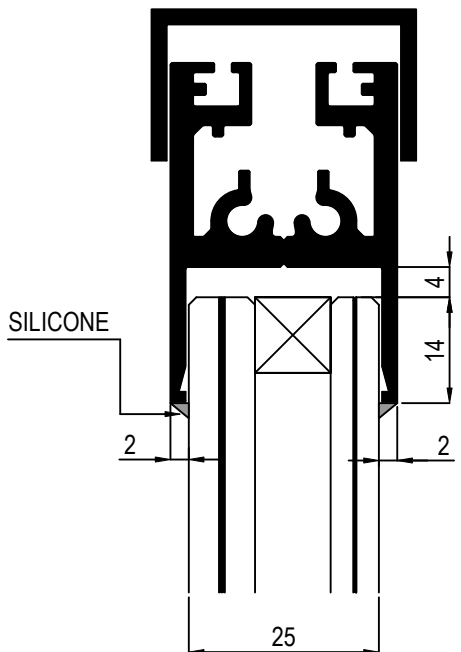

H CAMERA ANTIINTRUSIONE PA4 (EN356) 33.4/8/33.4

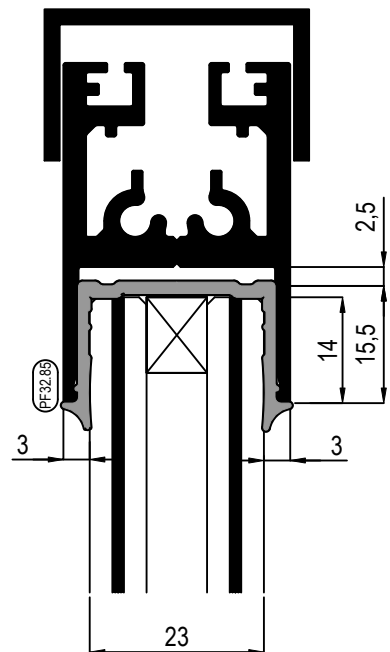

CODICE	DESCRIZIONE	Q.TA'	APPLICAZIONE
PF32.89	PATTINO ANTA SCOR. DX	1	SCORREVOLE
PF32.90	PATTINO ANTA SCOR. SX	1	SCORREVOLE
PF32.91	SQUADRETTI INTERNE	16	FISSA+SCOR.
PF32.93	KIT FISSAGGIO CARRELLI	2	SCORREVOLE
PF32.94	KIT VITI FISSAGGIO ANTA	4	FISSA+SCOR.

ACCESSORI

CODICE	DESCRIZIONE	Q.TA'	FORMULE	TAV. LAVORAZIONE	APPLICAZIONE
PF32.1	MONTANTE	4	HAF	M30-01+M30-05	FISSA
PF32.1	MONTANTE	4	HAS	M30-01+M30-02	SCORREVOLE
PF32.1	MONTANTE	1	LUP	-	FINITURA VANO
PF32.2	TRAVERSO	4	LAF-71	-	FISSA
PF32.2	TRAVERSO	4	LAS-80	-	SCORREVOLE
PF32.3	LABIRINTO	2	HAF	M30-07	FISSA
PF32.3	LABIRINTO	2	HAS	M30-03+M30-04+M30-07	SCORREVOLE
PF32.3	LABIRINTO	1	LUP	M30-07	FINITURA VANO
PF32.5	SOTTO TRAVERSO	2	LAF-71	-	FISSA
PF32.6	PROFILO AD "U" 35x20	1	L+20 (SOVRA METALLO)	-	FINITURA VANO
PF32.6	PROFILO AD "U" 35x20	2	H+20 (SOVRA METALLO)	-	FINITURA VANO
PF32.81	GURANIZIONE DI BATTUTA	1	HASx2	M30-06	SCORREVOLE
PF32.84	GUAR. VETRI STRATIFICATI	1	((LAF+HVF)+(LVS+HVS)+12)x4	-	FISSA+SCOR.
PF32.85	GUAR. VETRI CAMERA	1	((LAF+HVF)+(LVS+HVS)+12)x4	-	FISSA+SCOR.+VANO
PF32.86	SPAZ. MORBIDO H6mm	1	(HAF+HAS)x2-LUP	-	FISSA+SCOR.+VANO
PF32.87	SPAZ. MORBIDO H11mm	1	(HAF+HAS)x2-LUP	-	FISSA+SCOR.
PF32.88	SPAZ. RIGIDO H10mm	2	LAS-17	-	SCORREVOLE

PROFILI ALLUMINIO

SPAZZOLINI

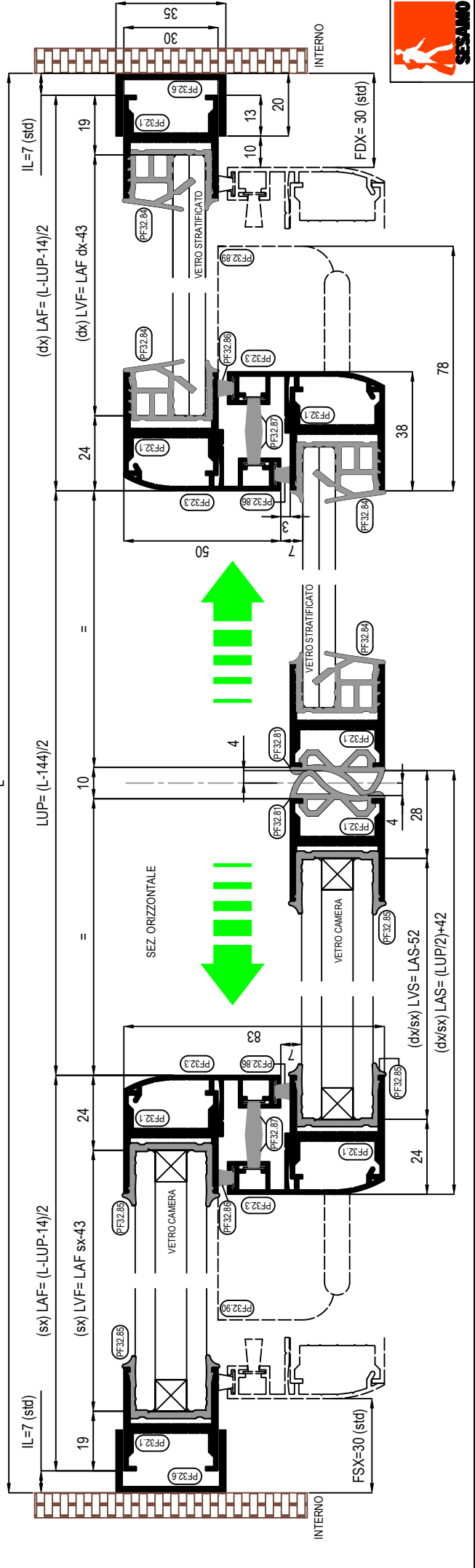
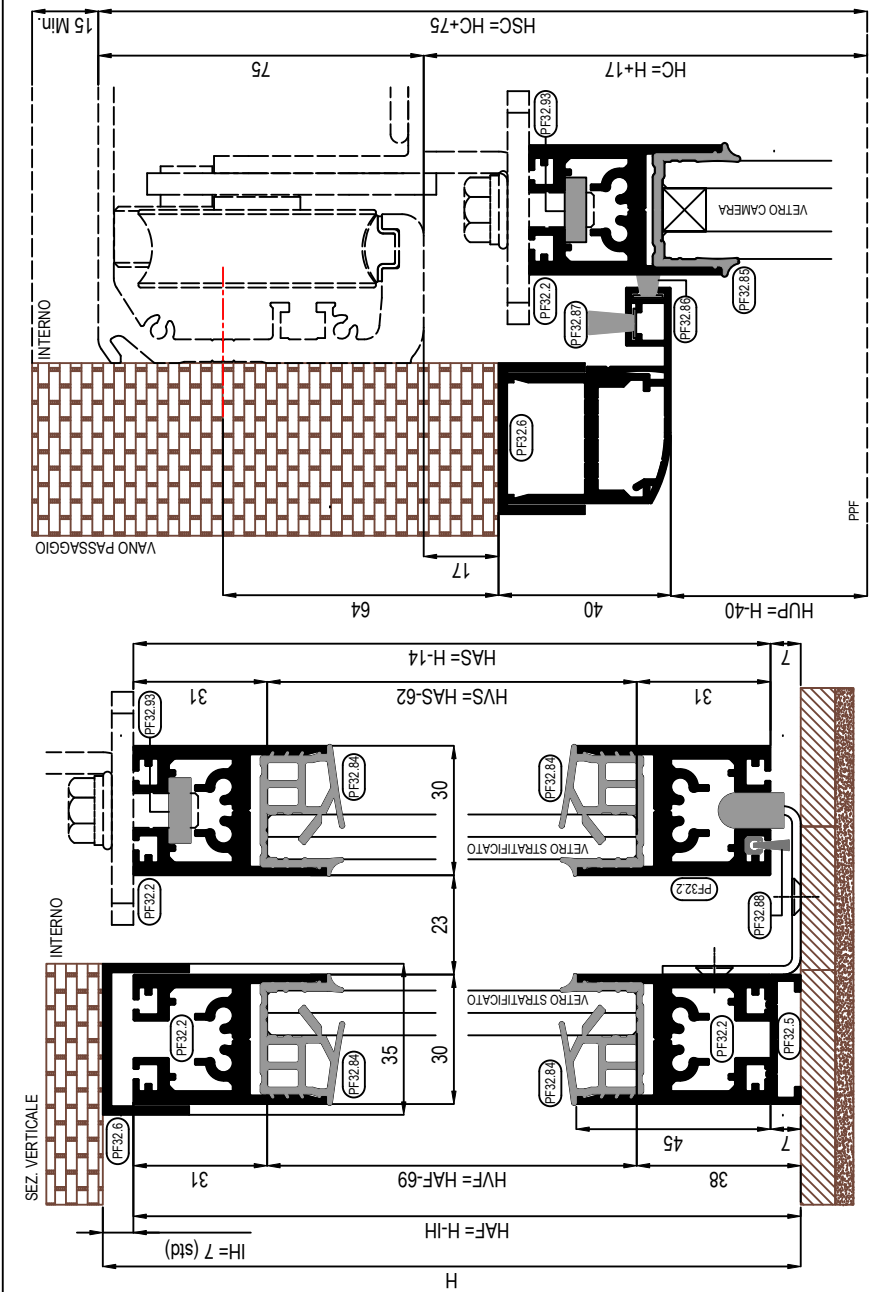

CODICE	DESCRIZIONE	Q.TA'	APPLICAZIONE
PF32.90	PATTINO ANTA SCOR. SX	1	SCORREVOLE
PF32.91	SQUADRETTA INTERNE	8	FISSA+SCOR.
PF32.93	KIT FISSAGGIO CARRELLI	1	SCORREVOLE
PF32.94	KIT VITI FISSAGGIO ANTA	2	FISSA+SCOR.

ACCESSORI

CODICE	DESCRIZIONE	Q.TA'	FORMULE	TAV. LAVORAZIONE	APPLICAZIONE
PF32.1	MONTANTE	2	HAF	M30-01+M30-05	FISSA
PF32.1	MONTANTE	2	HAS	M30-01+M30-02	SCORREVOLE
PF32.1	MONTANTE	1	LUP+17	-	FINITURA VANO
PF32.2	TRAVERSO	2	LAF-71	-	FISSA
PF32.2	TRAVERSO	2	LAS-80	-	SCORREVOLE
PF32.3	LABIRINTO	1	HAF	M30-07	FISSA
PF32.3	LABIRINTO	1	HAS	M30-03+M30-04+M30-07	SCORREVOLE
PF32.3	LABIRINTO	1	LUP+17	M30-07	FINITURA VANO
PF32.5	SOTTO TRAVERSO	1	LAF-71	-	FISSA
PF32.5	SOTTO TRAVERSO	1	HAS+7	-	BATTUTA
PF32.6	PROFILO AD "U" 35x20	1	L+20 ^(SOVRA METALLO)	-	FINITURA VANO
PF32.6	PROFILO AD "U" 35x20	1	H+20 ^(SOVRA METALLO)	-	FINITURA VANO
PF32.81	GURANIZIONE DI BATTUTA	1	(HASx2)+7	M30-06	SCORREVOLE
PF32.84	GUAR. VETRI STRATIFICATI	1	((LAF+HVF)+(LVS+HVS)+12)x2	FISSA+SCOR.	FISSA+SCOR.
PF32.85	GUAR. VETRI CAMERA	1	((LAF+HVF)+(LVS+HVS)+12)x2	FISSA+SCOR.+VANO	FISSA+SCOR.+VANO
PF32.86	SPAZ. MORBIDO H6mm	1	(HAF+HAS)x2-(LUP+17)	FISSA+SCOR.+VANO	FISSA+SCOR.+VANO
PF32.87	SPAZ. MORBIDO H11mm	1	(HAF+HAS)x2-(LUP+17)	FISSA+SCOR.	FISSA+SCOR.
PF32.88	SPAZ. RIGIDO H10mm	1	LAS-17	-	SCORREVOLE

PROFILI ALLUMINIO

GUARNIZIONI SPAZZOLINI

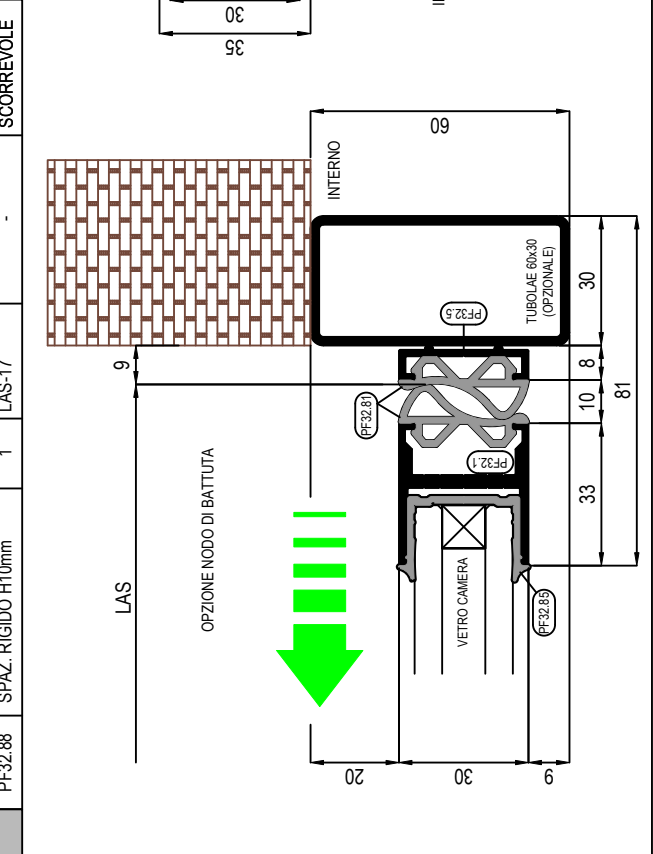
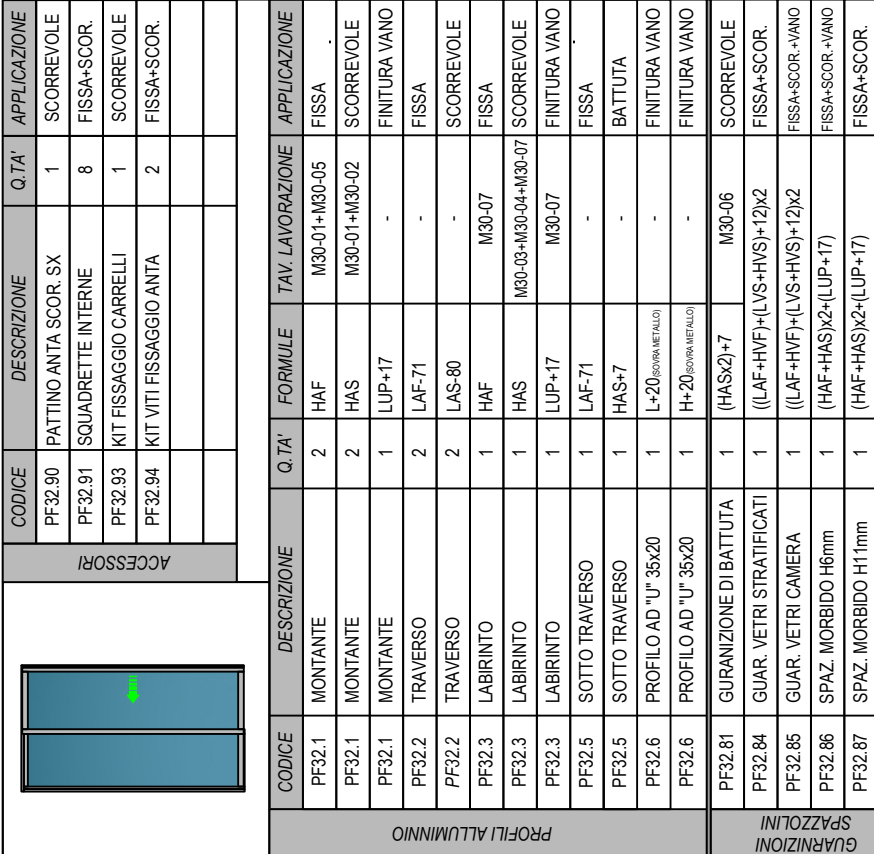
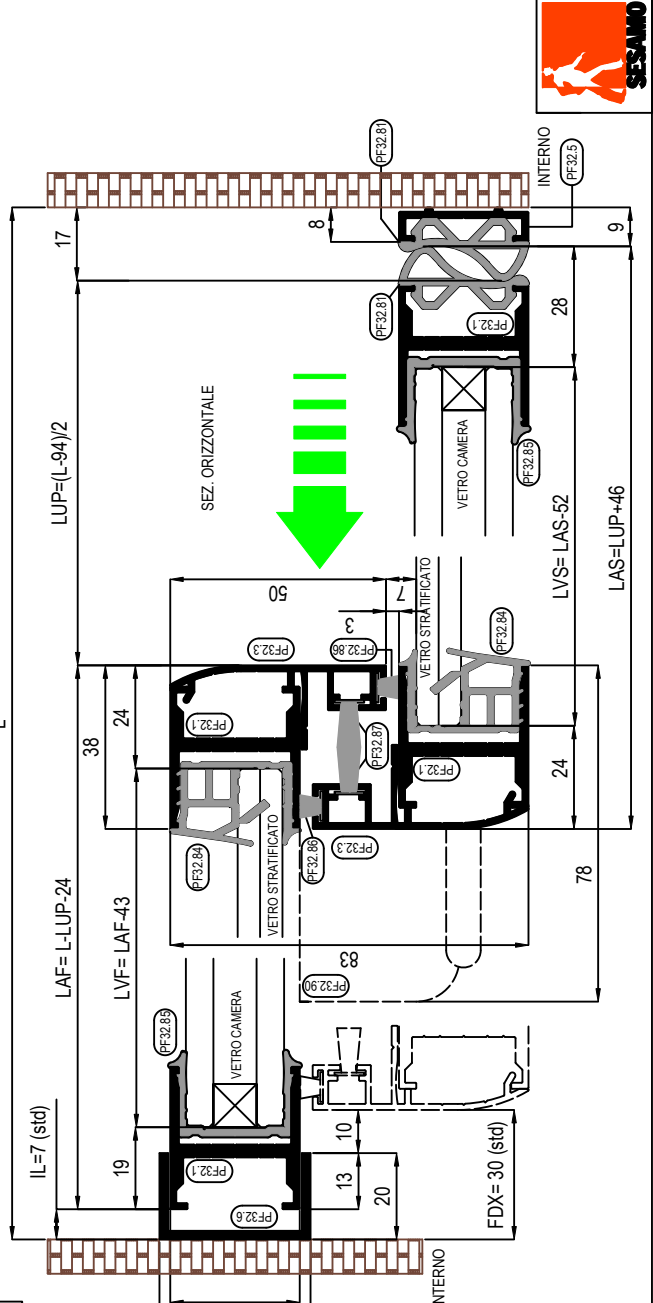
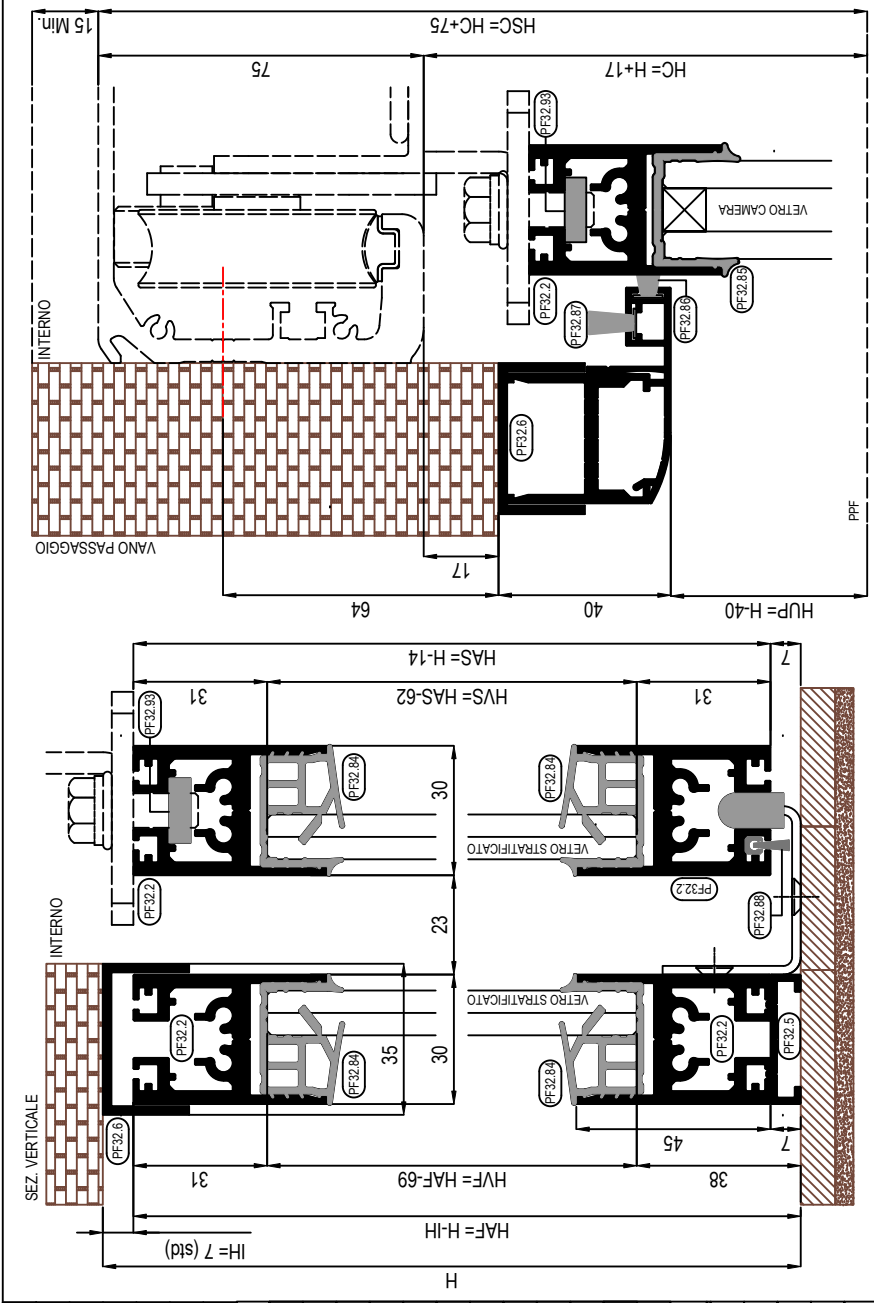

CODICE	DESCRIZIONE	Q.TA'	APPLICAZIONE
PF32.89	PATTINO ANTA SCOR. DX	1	SCORREVOLE
PF32.91	SQUADRETTI INTERNE	8	FISSA+SCOR.
PF32.93	KIT FISSAGGIO CARRELLI	1	SCORREVOLE
PF32.94	KIT VITI FISSAGGIO ANTA	2	FISSA+SCOR.

ACCESSORI

CODICE	DESCRIZIONE	Q.TA'	FORMULE	TAV. LAVORAZIONE	APPLICAZIONE
PF32.1	MONTANTE	2	HAF	M30-01+M30-05	FISSA
PF32.1	MONTANTE	2	HAS	M30-01+M30-02	SCORREVOLE
PF32.1	MONTANTE	1	LUP+17	-	FINITURA VANO
PF32.2	TRAVERSO	2	LAF-71	-	FISSA
PF32.2	TRAVERSO	2	LAS-80	-	SCORREVOLE
PF32.3	LABIRINTO	1	HAF	M30-07	FISSA
PF32.3	LABIRINTO	1	HAS	M30-03+M30-04+M30-07	SCORREVOLE
PF32.3	LABIRINTO	1	LUP+17	M30-07	FINITURA VANO
PF32.5	SOTTO TRAVERSO	1	LAF-71	-	FISSA
PF32.5	SOTTO TRAVERSO	1	HAS+7	-	BATTUTA
PF32.6	PROFILO AD "U" 35x20	1	L+20 ^(SOVRA METALLO)	-	FINITURA VANO
PF32.6	PROFILO AD "U" 35x20	1	H+20 ^(SOVRA METALLO)	-	FINITURA VANO
PF32.81	GURANIZIONE DI BATTUTA	1	(HASx2)+7	M30-06	SCORREVOLE
PF32.84	GUAR. VETRI STRATIFICATI	1	((LAF+HVF)+(LVS+HVS)+12)x2	FISSA+SCOR.	FISSA+SCOR.
PF32.85	GUAR. VETRI CAMERA	1	((LAF+HVF)+(LVS+HVS)+12)x2	FISSA+SCOR.+VANO	FISSA+SCOR.+VANO
PF32.86	SPAZ. MORBIDO H6mm	1	(HAF+HAS)x2-(LUP+17)	FISSA+SCOR.+VANO	FISSA+SCOR.+VANO
PF32.87	SPAZ. MORBIDO H11mm	1	(HAF+HAS)x2-(LUP+17)	FISSA+SCOR.	FISSA+SCOR.
PF32.88	SPAZ. RIGIDO H10mm	1	LAS-17	-	SCORREVOLE

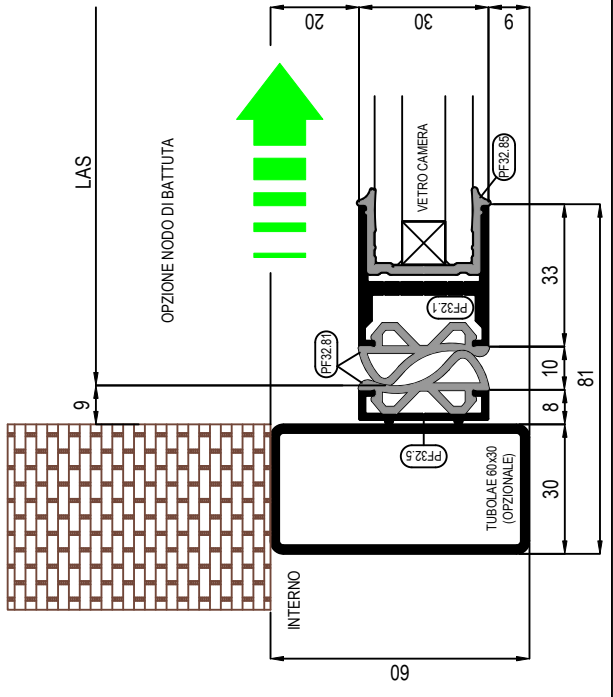
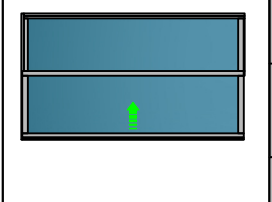
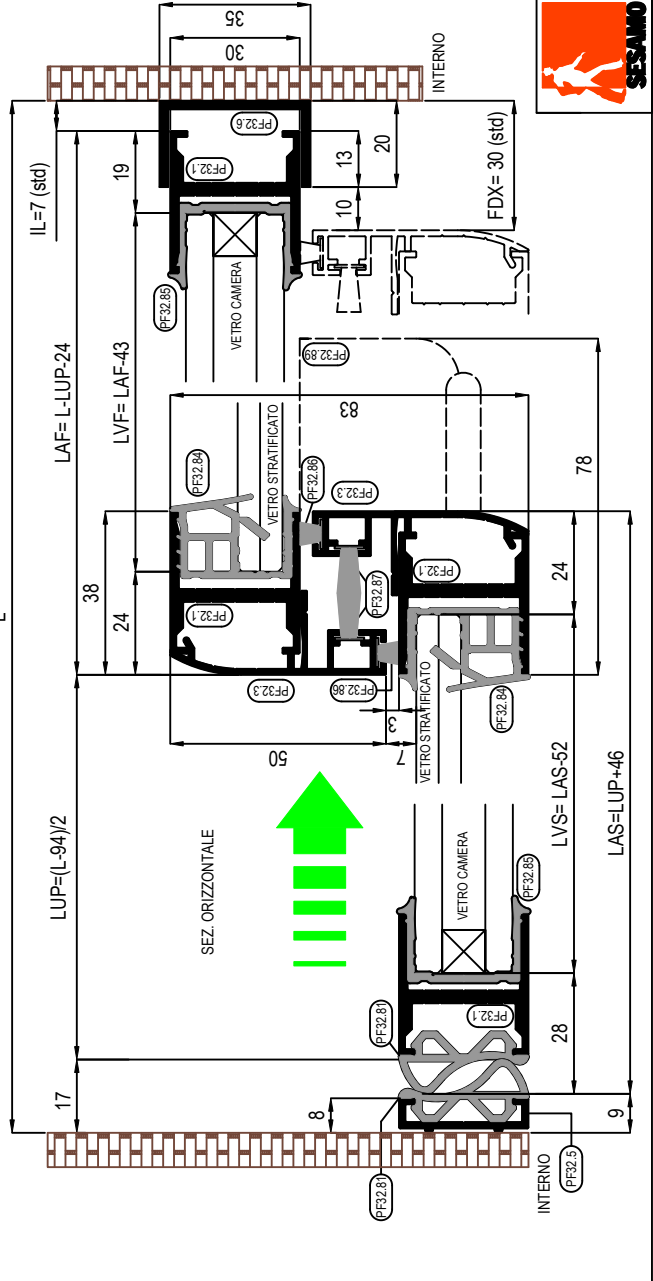
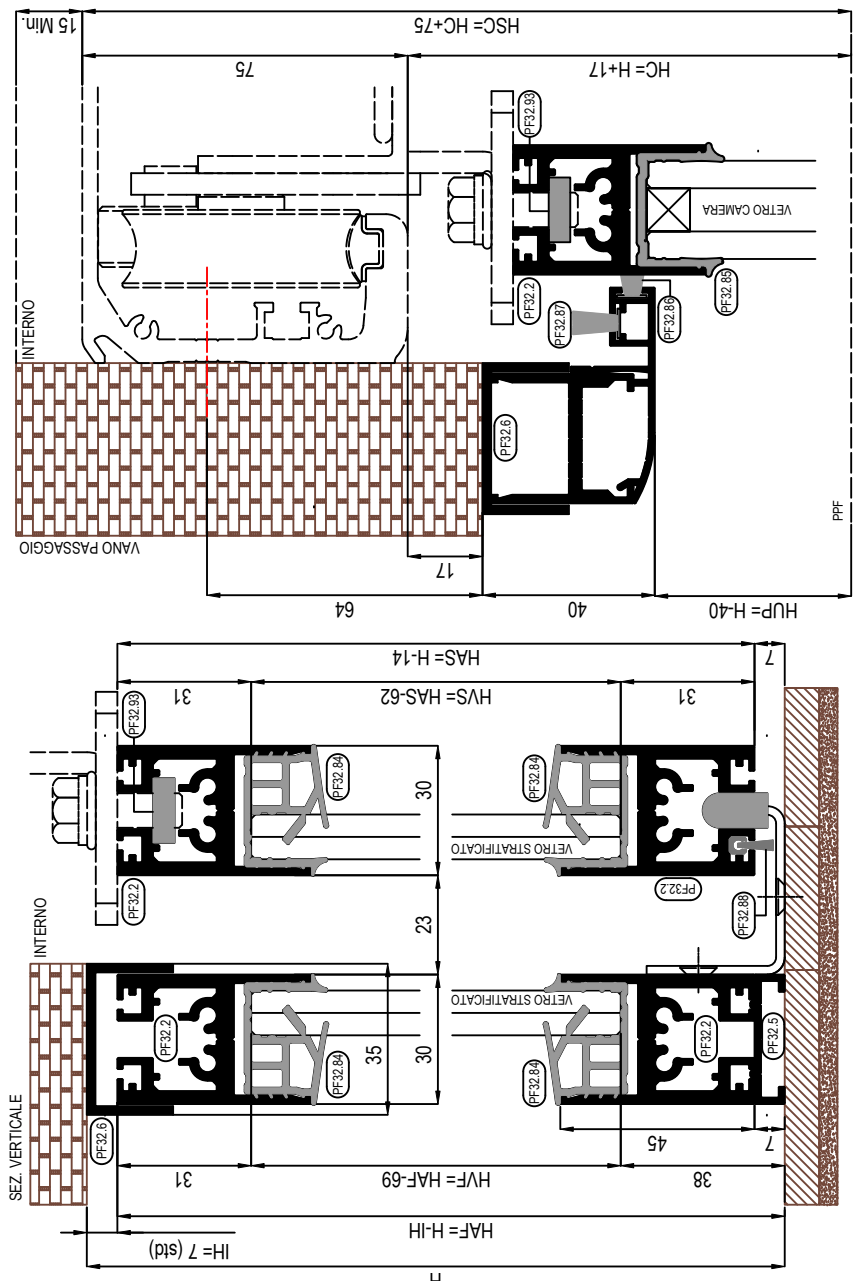

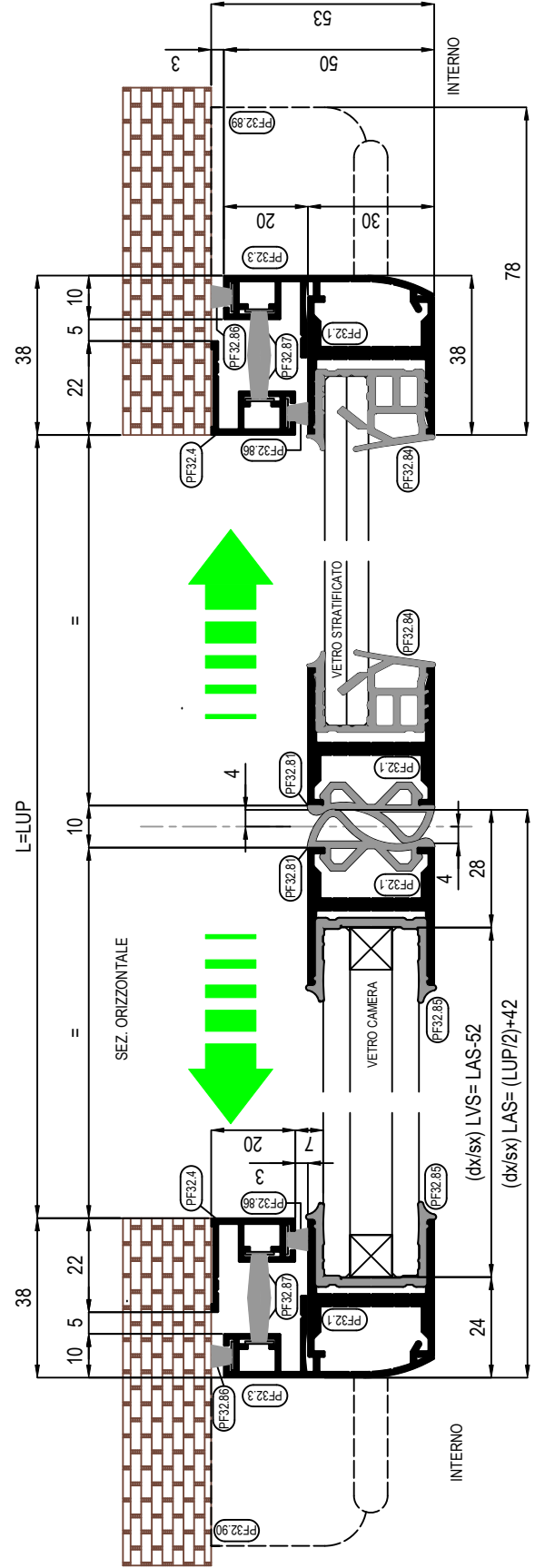
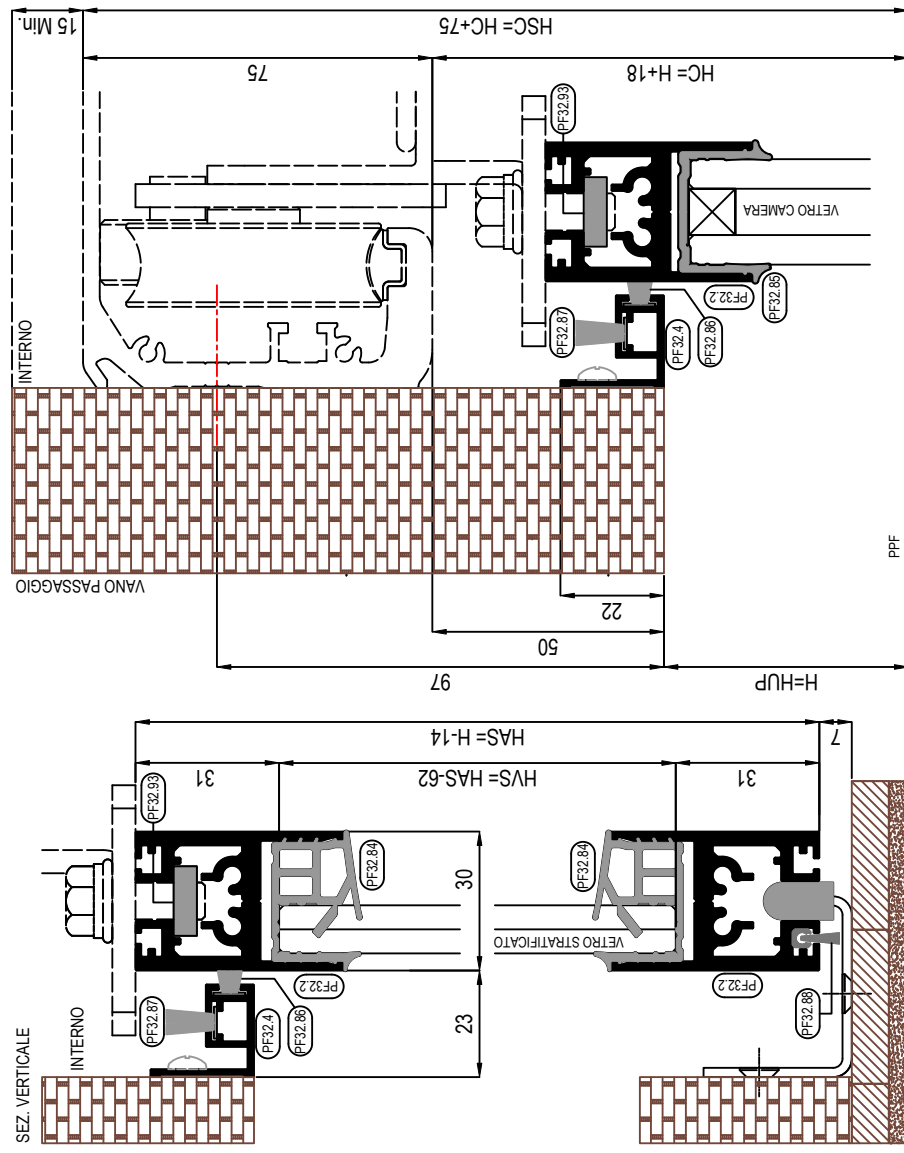

CODICE	DESCRIZIONE	Q. TA'	APPLICAZIONE
PF32.89	PATTINO ANTA SCOR. DX	1	SCORREVOLE
PF32.90	PATTINO ANTA SCOR. SX	1	SCORREVOLE
PF32.91	SQUADRETTE INTERNE	8	FISSA+SCOR.
PF32.93	KIT FISSAGGIO CARRELLI	2	SCORREVOLE
PF32.94	KIT VITI FISSAGGIO ANTA	2	FISSA+SCOR.

ACCESSORI

CODICE	DESCRIZIONE	Q. TA'	FORMULE	TAV. LAVORAZIONE	APPLICAZIONE
PF32.1	MONTANTE	4	HAS	M30-01+M30-02	SCORREVOLE
PF32.2	TRAVERSO	4	LAS-80	-	SCORREVOLE
PF32.3	LABIRINTO	2	HAS	M30-03+M30-04+M30-07	SCORREVOLE
PF32.4	CORNICE	2	HUP	-	FINITURA VANO
PF32.4	CORNICE	1	L+20	-	FINITURA VANO
PF32.81	GURANIZIONE DI BATTUTA	1	HASx2	M30-06	SCORREVOLE
PF32.84	GUAR. VETRI STRATIFICATI	1	((LVS+HVS+6)x2)x2		SCORREVOLE
PF32.85	GUAR. VETRI CAMERA	1	((LVS+HVS+6)x2)x2		SCORREVOLE
PF32.86	SPAZ. MORBIDO H6mm	1	(HASx2)+(L+20)+(HUPx2)		VANO+SCOR.
PF32.87	SPAZ. MORBIDO H11mm	1	(HASx2)+(L+20)+(HUPx2)		VANO+SCOR.
PF32.88	SPAZ. RIGIDO H10mm	2	LAS-17	-	SCORREVOLE

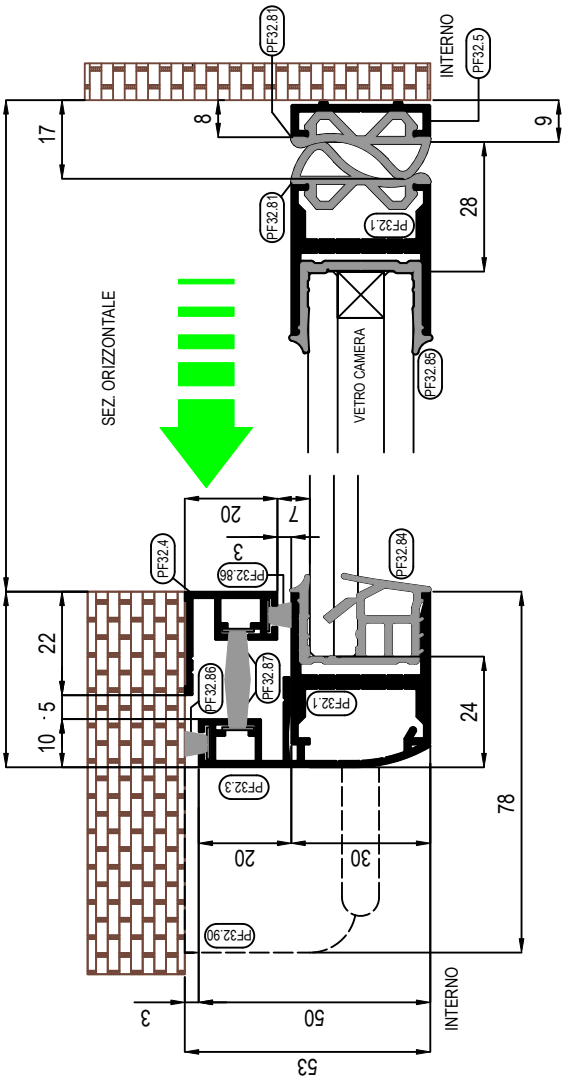
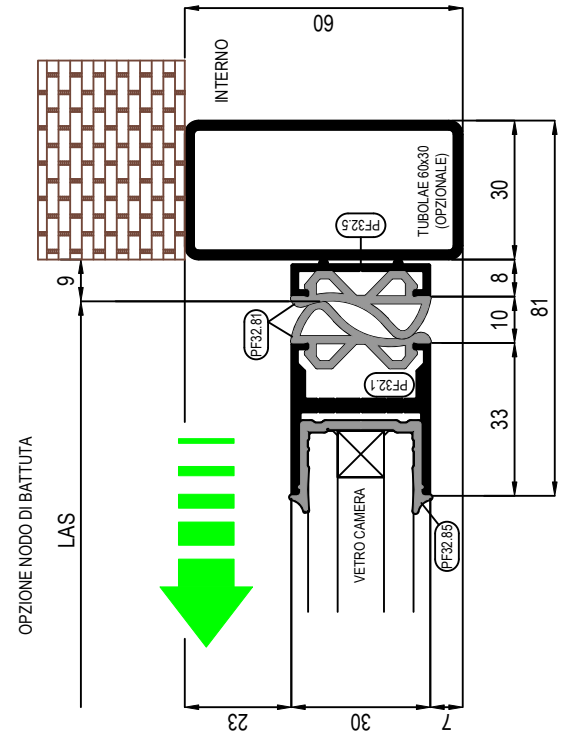
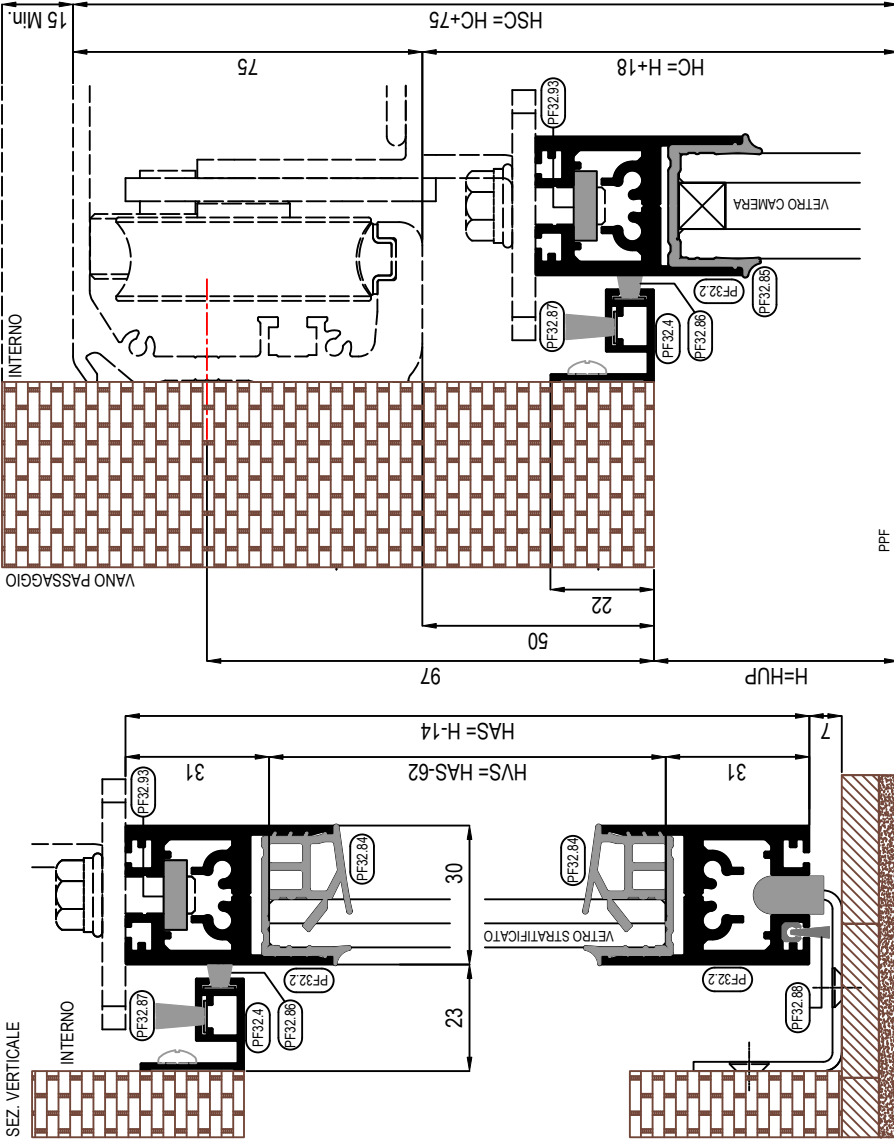

CODICE	DESCRIZIONE	Q.TA'	FORMULE	TAV. LAVORAZIONE	APPLICAZIONE
PF32.90	PATTINO ANTA SCOR. SX	1			SCORREVOLE
PF32.91	SQUADRETTE INTERNE	4			SCORREVOLE
PF32.93	KIT FISSAGGIO CARRELLI	1			SCORREVOLE
PF32.94	KIT VITI FISSAGGIO ANTA	1			SCORREVOLE
ACCESSORI					
CODICE	DESCRIZIONE	Q.TA'	FORMULE	TAV. LAVORAZIONE	APPLICAZIONE
PF32.1	MONTANTE	2	HAS	M30-01+M30-02	SCORREVOLE
PF32.2	TRAVERSO	2	LAS-80	-	SCORREVOLE
PF32.3	LABIRINTO	1	HAS	M30-03+M30-04+M30-07	SCORREVOLE
PF32.5	SOTTO TRAVERSO	1	HAS+7	-	BATTUTA
PF32.4	CORNICE	1	HUP	-	FINITURA VANO
PF32.4	CORNICE	1	L+10	-	FINITURA VANO
PF32.81	GURANIZIONE DI BATTUTA	1	(HASx2)+7	M30-06	SCOR.+BATTUTA
PF32.84	GUAR. VETRI STRATIFICATI	1	(LVS+HVS+6)x2		SCORREVOLE
PF32.85	GUAR. VETRI CAMERA	1	(LVS+HVS+6)x2		SCORREVOLE
PF32.86	SPAZ. MORBIDO H6mm	1	HAS+(L+10)+HUP		VANO+SCOR.
PF32.87	SPAZ. MORBIDO H11mm	1	HAS+(L+10)+HUP		VANO+SCOR.
PF32.88	SPAZ. RIGIDO H10mm	1	LAS-17		SCORREVOLE
PROFILI ALLUMINIO					
GUARNIZIONI					

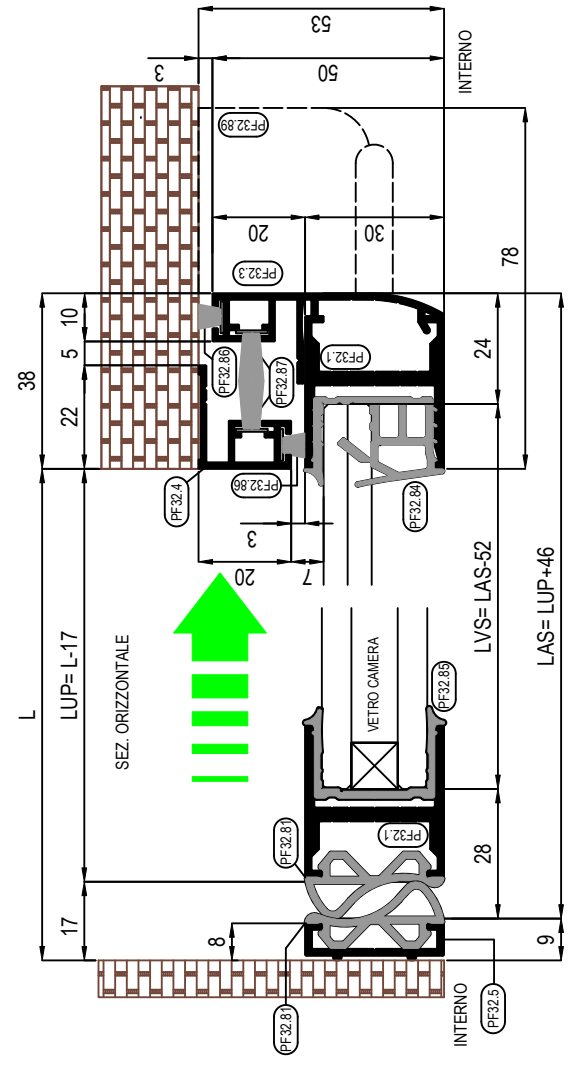
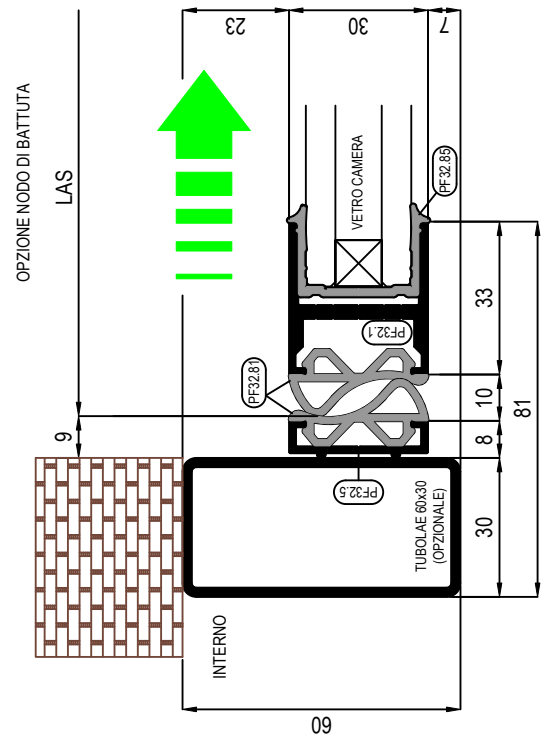
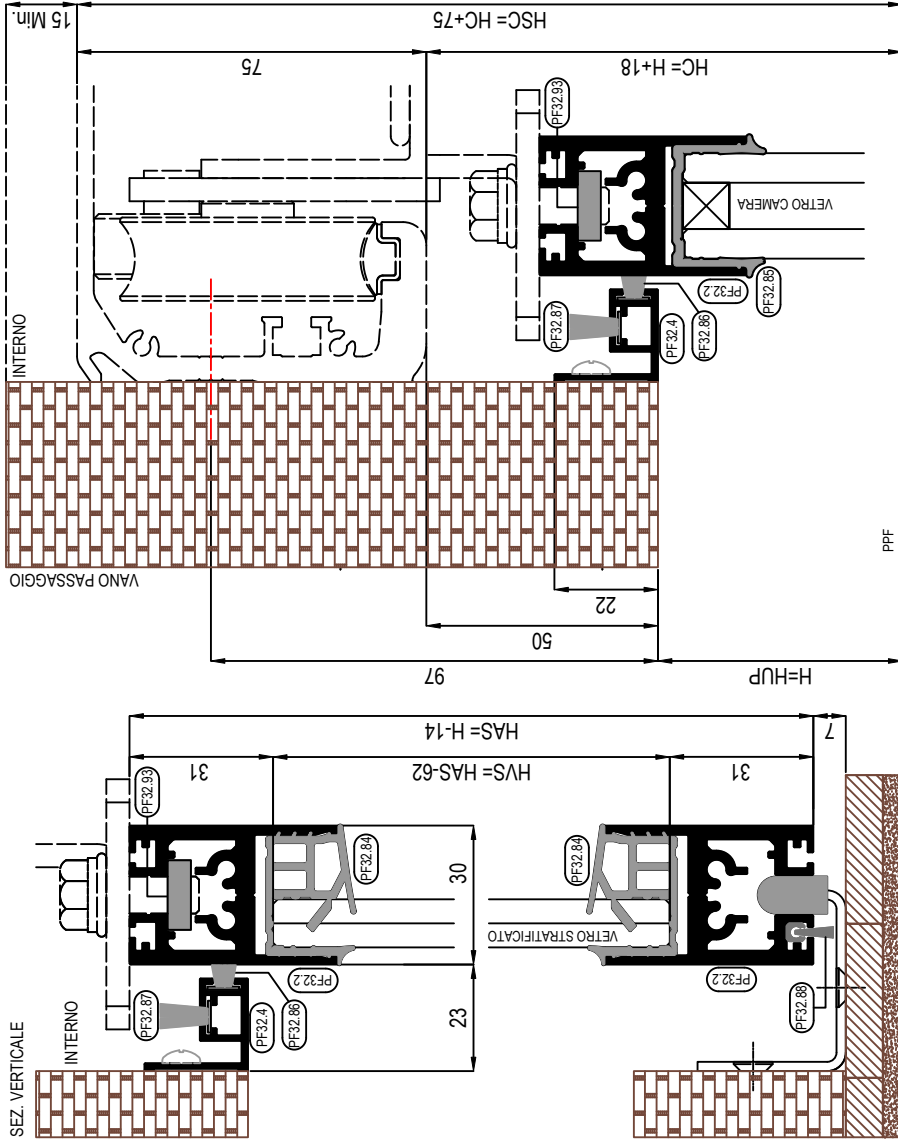

ACCESSORI		CODICE	DESCRIZIONE	Q.TA'	FORMULE	TAV. LAVORAZIONE	APPLICAZIONE
		PF32.89	PATTINO ANTA SCOR. DX	1			SCORREVOLE
		PF32.91	SQUADRETTE INTERNE	4			SCORREVOLE
		PF32.93	KIT FISSAGGIO CARRELLI	1			SCORREVOLE
		PF32.94	KIT VITI FISSAGGIO ANTA	1			SCORREVOLE
PROFILI ALLUMINIO							
CODICE	DESCRIZIONE	Q.TA'	FORMULE	TAV. LAVORAZIONE	APPLICAZIONE		
PF32.1	MONTANTE	2	HAS	M30-01+M30-02	SCORREVOLE		
PF32.2	TRAVERSO	2	LAS-80	-	SCORREVOLE		
PF32.3	LABIRINTO	1	HAS	M30-03+M30-04+M30-07	SCORREVOLE		
PF32.5	SOTTO TRAVERSO	1	HAS-7	-	BATTUTA		
PF32.4	CORNICE	1	HUP	-	FINITURA VANO		
PF32.4	CORNICE	1	L+10	-	FINITURA VANO		
GUARNIZIONI							
PF32.81	GURANIZIONE DI BATTUTA	1	(HASx2)+7	M30-06	SCOR.+BATTUTA		
PF32.84	GUAR. VETRI STRATIFICATI	1	(LVS+HVS+6)x2		SCORREVOLE		
PF32.85	GUAR. VETRI CAMERA	1	(LVS+HVS+6)x2		SCORREVOLE		
PF32.86	SPAZ. MORBIDO H6mm	1	HAS+(L+10)+HUP		VANO+SCOR.		
PF32.87	SPAZ. MORBIDO H11mm	1	HAS+(L+10)+HUP		VANO+SCOR.		
PF32.88	SPAZ. RIGIDO H10mm	1	LAS-17		SCORREVOLE		

ACCESSORI		CODICE	DESCRIZIONE	Q.TA'	DESCRIZIONE	Q.TA'	APPLICAZIONE
		PF32.89	PATTINO ANTA SCOR. DX	2	SCORREVOLI		
		PF32.90	PATTINO ANTA SCOR. SX	2	SCORREVOLI		
		PF32.91	SQUADRETTI INTERNE	24	FISSA+SCOR.		
		PF32.93	KIT FISSAGGIO CARRELLI	4	SCORREVOLI		
		PF32.94	KIT VITI FISSAGGIO ANTA	6	FISSA+SCOR.		
PROFILI ALLUMINIO		CODICE	DESCRIZIONE	Q.TA'	FORMULE	TAV. LAVORAZIONE	APPLICAZIONE
		PF32.1	MONTANTE	4	HAF	M30-01+M30-05	FISSA
		PF32.1	MONTANTE	4	HASL	M30-01+M30-02	SCOR. LENTA
		PF32.1	MONTANTE	4	HASV	M30-01+M30-02	SCOR. VELOCE
		PF32.1	MONTANTE	1	LUP	-	FINITURA VANO
		PF32.2	TRAVERSO	4	LAF-71	-	FISSA
		PF32.2	TRAVERSO	8	LASL-76	-	SCORR. (V+L)
		PF32.3	LABIRINTO	2	HAF	M30-07	FISSA
		PF32.3	LABIRINTO	4	HASL	M30-03+M30-04+M30-07	SCORR. LENTA
		PF32.3	LABIRINTO	2	HASV	M30-03 + M30-07	SCORR. VELOCE
		PF32.3	LABIRINTO	1	LUP	M30-07	FINITURA VANO
		PF32.5	SOTTO TRAVERSO	2	LAF-71	-	FISSA
		PF32.6	PROFILO AD "U" 35x20	1	L+20 (SOPRA METALLO)	-	FINITURA VANO.
		PF32.6	PROFILO AD "U" 35x20	2	H+20 (SOTTO METALLO)	-	FINITURA VANO
GUARNIZIONI		CODICE	DESCRIZIONE	Q.TA'	FORMULE	TAV. LAVORAZIONE	APPLICAZIONE
		PF32.81	GURANIZIONE DI BATTUTA	1	HASVx2	M30-06	SCORR. VELOCI
		PF32.84	GUAR. VETRI STRATIFICATI	1	((HVS+L+VSI)+(HVS+L+VSI)+(HVFL+VFI)+18)x4		FISSA+SCOR.
		PF32.85	GUAR. VETRI CAMERA	1	((HVS+L+VSI)+(HVS+L+VSI)+(HVFL+VFI)+18)x4		FISSA+SCOR.
		PF32.86	SPAZ. MORBIDO H6mm	1	(HAF-2)+(HASLx4)+(HASVx2)+LUP		FISSA+SCOR.+VANO
		PF32.87	SPAZ. MORBIDO H11mm	1	(HAF-2)+(HASLx4)+(HASVx2)+LUP		FISSA+SCOR.+VANO
		PF32.88	SPAZ. RIGIDO H10mm	2	LASL-17	-	SCOR. LENTA
		PF32.88	SPAZ. RIGIDO H10mm	2	LASV-17	-	SCOR. VELOCE

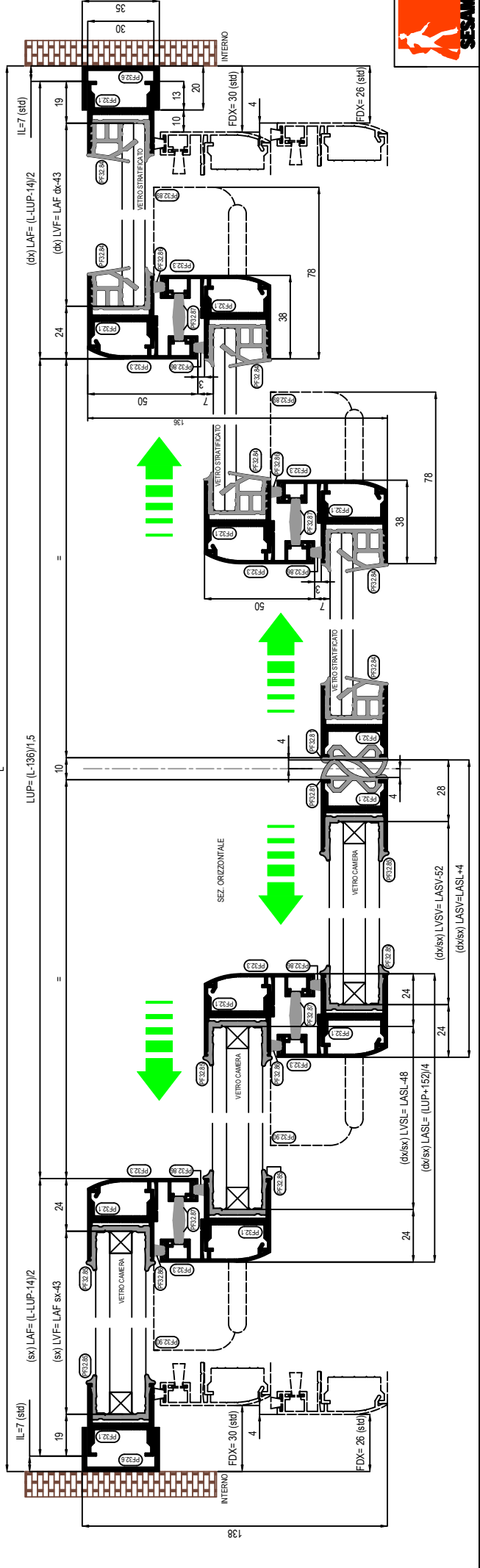
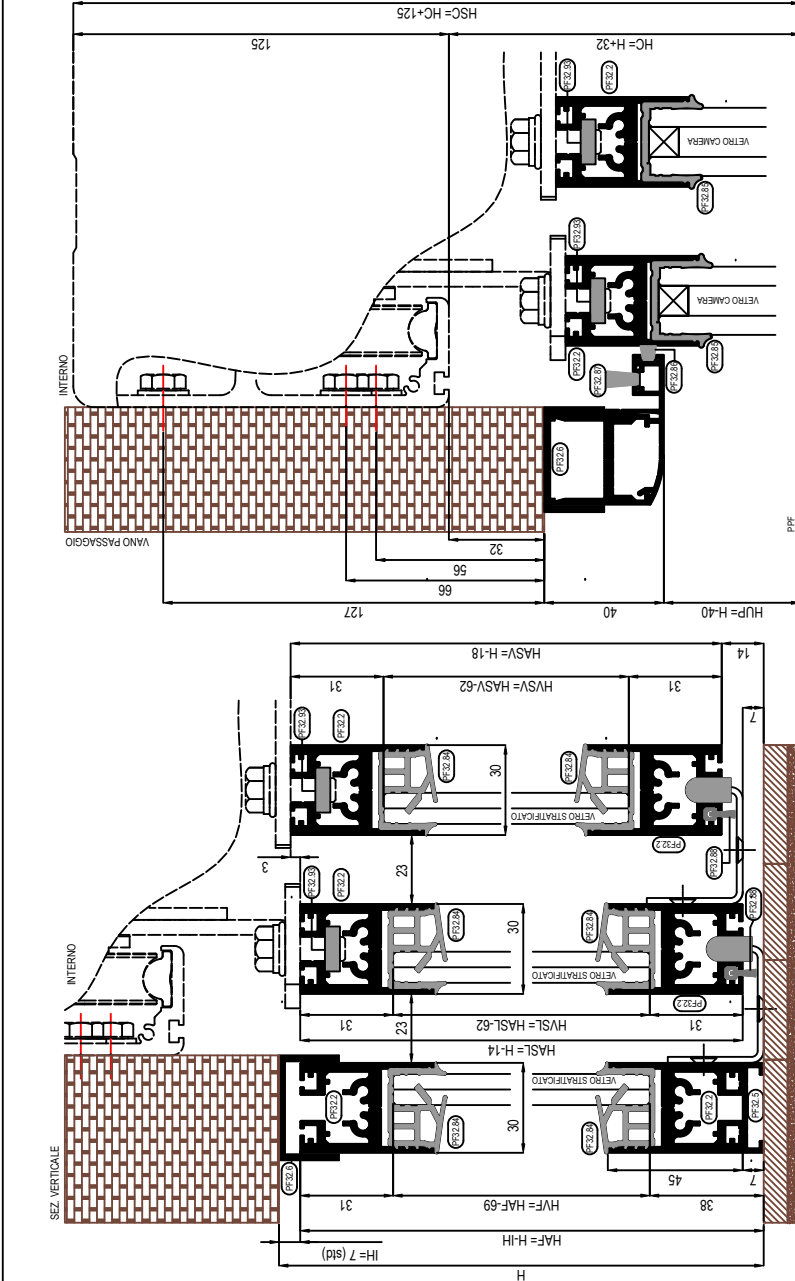

CODICE	DESCRIZIONE	FORMULE	TAV. LAVORAZIONE	Q.TA'	APPLICAZIONE
PF32.90	PATTINO ANTA SCOR. SX	HAF	M30-01+M30-05	2	SCORREVOLI
PF32.91	SQUADRETTE INTERNE	HASL	M30-01+M30-02	12	FISSA+SCOR.
PF32.93	KIT FISSAGGIO CARRELLI	HASV	M30-01+M30-02	2	SCORREVOLI
PF32.94	KIT VITI FISSAGGIO ANTA	LUP+17	-	3	FISSA+SCOR.
ACCESSORI					
CODICE	DESCRIZIONE	FORMULE	TAV. LAVORAZIONE	Q.TA'	APPLICAZIONE
PF32.1	MONTANTE	HAF	M30-01+M30-05	2	FISSA
PF32.1	MONTANTE	HASL	M30-01+M30-02	2	SCOR. LENTA
PF32.1	MONTANTE	HASV	M30-01+M30-02	2	SCOR. VELOCE
PF32.1	MONTANTE	LUP+17	-	1	FINITURA VANO
PF32.2	TRAVERSO	LAF-71	-	2	FISSA
PF32.2	TRAVERSO	LASL-76	-	4	SCORR. (V+L)
PF32.3	LABIRINTO	HAF	M30-07	2	FISSA
PF32.3	LABIRINTO	HASL	M30-03+M30-04+M30-07	2	SCORR. LENTA
PF32.3	LABIRINTO	HASV	M30-03 + M30-07	1	SCORR. VELOCE
PF32.3	LABIRINTO	LUP+17	M30-07	1	FINITURA VANO
PF32.5	SOOTTO TRAVERSO	LAF-71	-	1	FISSA
PF32.5	SOOTTO TRAVERSO	HASV+14	-	1	BATTUTA
PF32.6	PROFILO AD "U" 35x20	L+20 (OPAZIONE TALLO)	-	1	FINITURA VANO
PF32.6	PROFILO AD "U" 35x20	H+20 (OPAZIONE TALLO)	-	1	FINITURA VANO
PF32.81	GURANIZIONE DI BATTUTA	(HASVx2)+14	M30-06	1	SCOR.+BATTUTA
PF32.84	GUAR. VETRI STRATIFICATI	((HVS)+(LVS)+(HVS)+(LVS)+(HVF+LVF+19)x2	-	1	FISSA+SCOR.
PF32.85	GUAR. VETRI CAMERA	((HVS)+(LVS)+(HVS)+(LVS)+(HVF+LVF+19)x2	-	1	FISSA+SCOR.
PF32.86	SPAZ. MORRIDO H6mm	HAF+(HASLx2)+HASV+(LUP+17)	-	1	FISSA+SCOR.+VANO
PF32.87	SPAZ. MORRIDO H11mm	HAF+(HASLx2)+HASV+(LUP+17)	-	1	FISSA+SCOR.+VANO
PF32.88	SPAZ. RIGIDO H10mm	LASL-17	-	1	SCOR. LENTA
PF32.88	SPAZ. RIGIDO H10mm	LASV-17	-	1	SCOR. VELOCE

PROFILI ALLUMINIO

GUARNIZIONI SPAZZOLINI

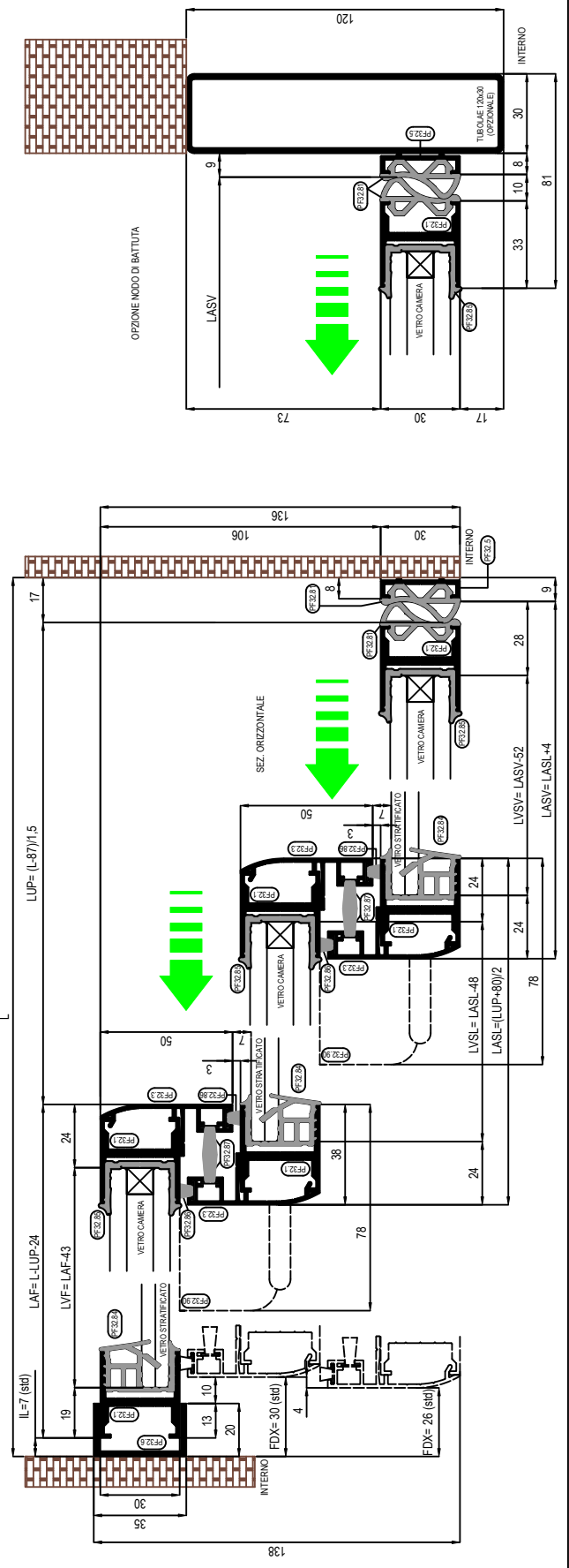
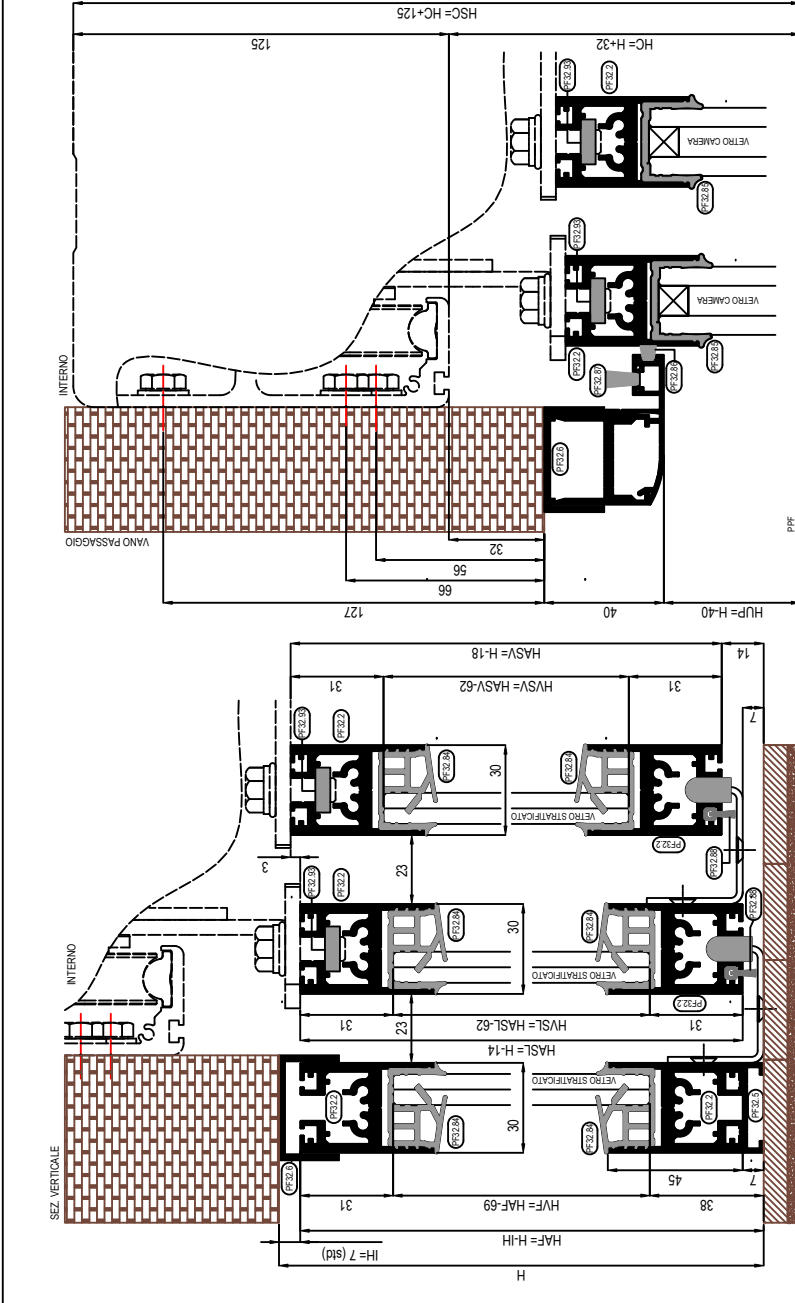

CODICE	DESCRIZIONE	FORMULE	TAV. LAVORAZIONE	APPLICAZIONE	Q.TA'	APPLICAZIONE
PF32.89	PATTINO ANTA SCOR. DX	HAF	M30-01+M30-05	SCORREVOLI	2	SCORREVOLI
PF32.91	SQUADRETTI INTERNE	HASL	M30-01+M30-02	FISSA+SCOR.	12	FISSA+SCOR.
PF32.93	KIT FISSAGGIO CARRELLI	HASV	M30-01+M30-02	SCORREVOLI	2	SCORREVOLI
PF32.94	KIT VITI FISSAGGIO ANTA	LUP+17	-	FISSA+SCOR.	3	FISSA+SCOR.
ACCESSORI						
CODICE	DESCRIZIONE	FORMULE	TAV. LAVORAZIONE	APPLICAZIONE	Q.TA'	APPLICAZIONE
PF32.1	MONTANTE	HAF	M30-01+M30-05	FISSA	2	FISSA
PF32.1	MONTANTE	HASL	M30-01+M30-02	SCOR. LENTA	2	SCOR. LENTA
PF32.1	MONTANTE	HASV	M30-01+M30-02	SCOR. VELOCE	2	SCOR. VELOCE
PF32.1	MONTANTE	LUP+17	-	FINITURA VANO	1	FINITURA VANO
PF32.2	TRAVERSO	LAF-71	-	FISSA	2	FISSA
PF32.2	TRAVERSO	LASF-76	-	SCORR. (V+L)	4	SCORR. (V+L)
PF32.3	LABIRINTO	HAF	M30-07	FISSA	2	FISSA
PF32.3	LABIRINTO	HASL	M30-03+M30-04+M30-07	SCORR. LENTA	2	SCORR. LENTA
PF32.3	LABIRINTO	HASV	M30-03 + M30-07	SCORR. VELOCE	1	SCORR. VELOCE
PF32.3	LABIRINTO	LUP+17	M30-07	FINITURA VANO	1	FINITURA VANO
PF32.5	SOTTO TRAVERSO	LAF-71	-	FISSA	1	FISSA
PF32.5	SOTTO TRAVERSO	HASV+14	-	BATTUTA	1	BATTUTA
PF32.6	PROFILO AD "U" 35x20	L+20 ^(OPZIONALE)	-	FINITURA VANO	1	FINITURA VANO
PF32.6	PROFILO AD "U" 35x20	H+20 ^(OPZIONALE)	-	FINITURA VANO	1	FINITURA VANO
PF32.81	GURANIZIONE DI BATTUTA	(HASVx2)+14	M30-06	SCOR.+BATTUTA	1	SCOR.+BATTUTA
PF32.84	GUAR. VETRI STRATIFICATI	((HVS)+LVS)+HVS+HVS+HVF+LVF+19)x2	-	FISSA+SCOR.	1	FISSA+SCOR.
PF32.85	GUAR. VETRI CAMERA	((HVS)+LVS)+HVS+HVS+HVF+LVF+19)x2	-	FISSA+SCOR.	1	FISSA+SCOR.
PF32.86	SPAZ. MORIBIDO H6mm	HAF+(HASLx2)+HASV+(LUP+17)	-	FISSA+SCOR.+VANO	1	FISSA+SCOR.+VANO
PF32.87	SPAZ. MORIBIDO H11mm	HAF+(HASLx2)+HASV+(LUP+17)	-	FISSA+SCOR.+VANO	1	FISSA+SCOR.+VANO
PF32.88	SPAZ. RIGIDO H10mm	LASL-17	-	SCOR. LENTA	1	SCOR. LENTA
PF32.88	SPAZ. RIGIDO H10mm	LASV-17	-	SCOR. VELOCE	1	SCOR. VELOCE

PROFILI ALLUMINIO

GUARNIZIONI SPAZZOLINI

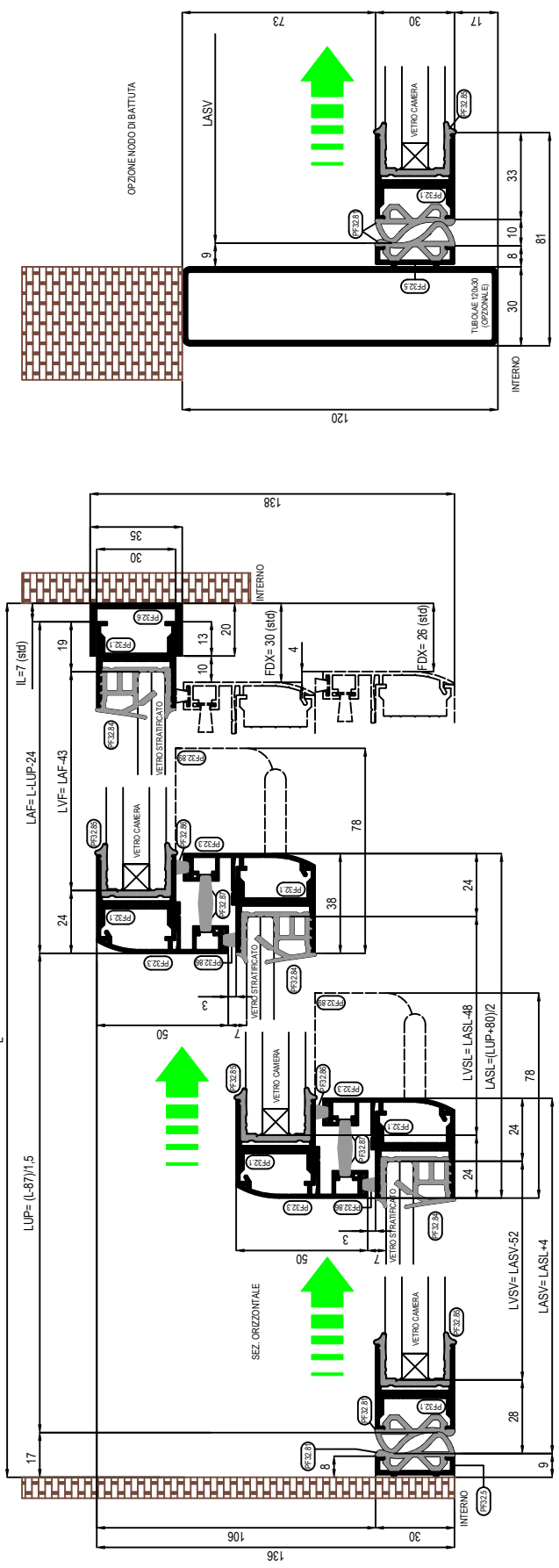
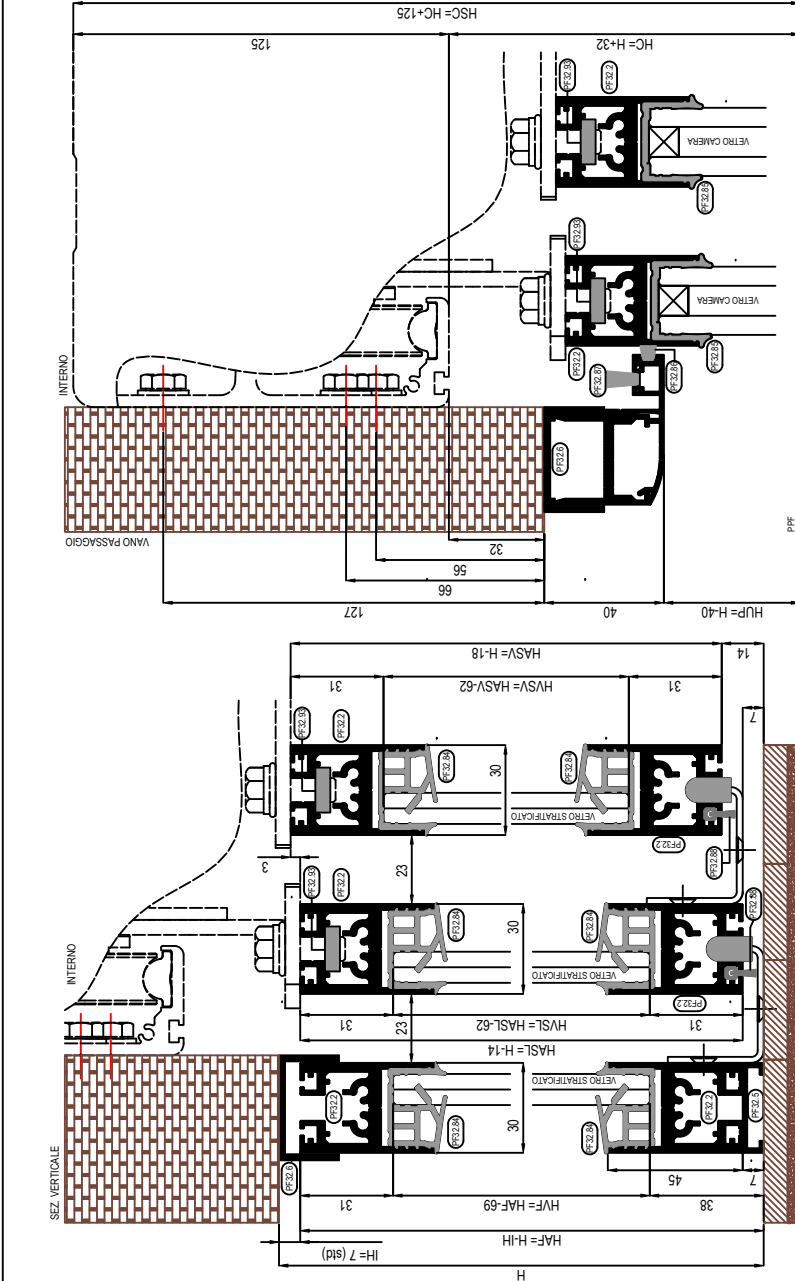

CODICE	DESCRIZIONE	Q.TA'	APPLICAZIONE
PF32.89	PATTINO ANTA SCOR. DX	2	SCORREVOLI
PF32.90	PATTINO ANTA SCOR. SX	2	SCORREVOLI
PF32.91	SQUADRETTE INTERNE	16	FISSA+SCOR.
PF32.93	KIT FISSAGGIO CARRELLI	4	SCORREVOLI
PF32.94	KIT VITI FISSAGGIO ANTA	4	FISSA+SCOR.

ACCESSORI

CODICE	DESCRIZIONE	Q.TA'	FORMULE	TAV. LAVORAZIONE	APPLICAZIONE
PF32.1	MONTANTE	4	HASL	M30-01+M30-02	SCOR. LENTA
PF32.1	MONTANTE	4	HASV	M30-01+M30-02	SCOR. VELOCE
PF32.2	TRAVERSO	8	LASL-76	-	SCORREVOLE
PF32.3	LABIRINTO	4	HASL	M30-03+M30-07	SCOR. LENTA
PF32.3	LABIRINTO	2	HASV	M30-03+M30-07	SCOR. VELOCE
PF32.4	CORNICE	2	H	-	FINITURA VANO
PF32.4	CORNICE	1	L+20	-	FINITURA VANO
PF32.81	GURANIZIONE DI BATTUTA	1	HASVx2	M30-06	SCOR. VELOCI
PF32.84	GUAR. VETRI STRATIFICATI	1	((HVSL+LVSL)+(HVSV+LVSV)+12)x4	-	SCORREVOLE
PF32.85	GUAR. VETRI CAMERA	1	((HVSL+LVSL)+(HVSV+LVSV)+12)x4	-	SCORREVOLE
PF32.86	SPAZ. MORBIDO H6mm	1	((HASLx4)+(HASCx2)+(HX2)+(LUP+20)	-	VANO+SCOR.
PF32.87	SPAZ. MORBIDO H11mm	1	((HASLx4)+(HASCx2)+(HX2)+(LUP+20)	-	VANO+SCOR.
PF32.88	SPAZ. RIGIDO H10mm	2	LASL-17	-	SCOR. LENTA
PF32.88	SPAZ. RIGIDO H10mm	2	LASV-17	-	SCOR. VELOCE

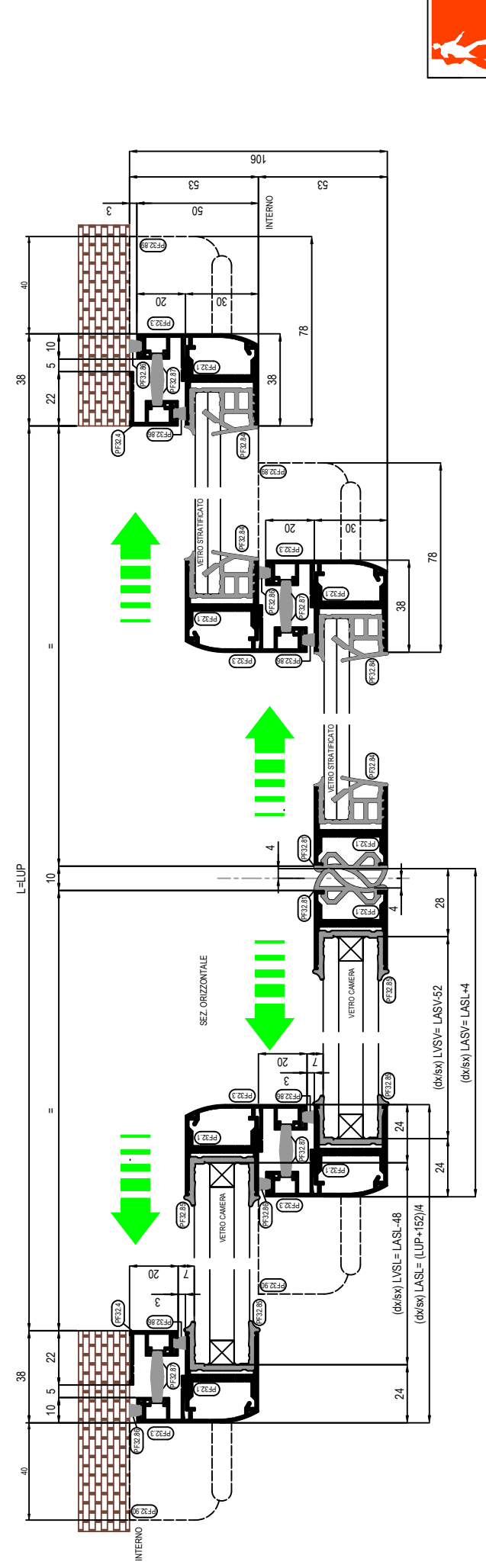
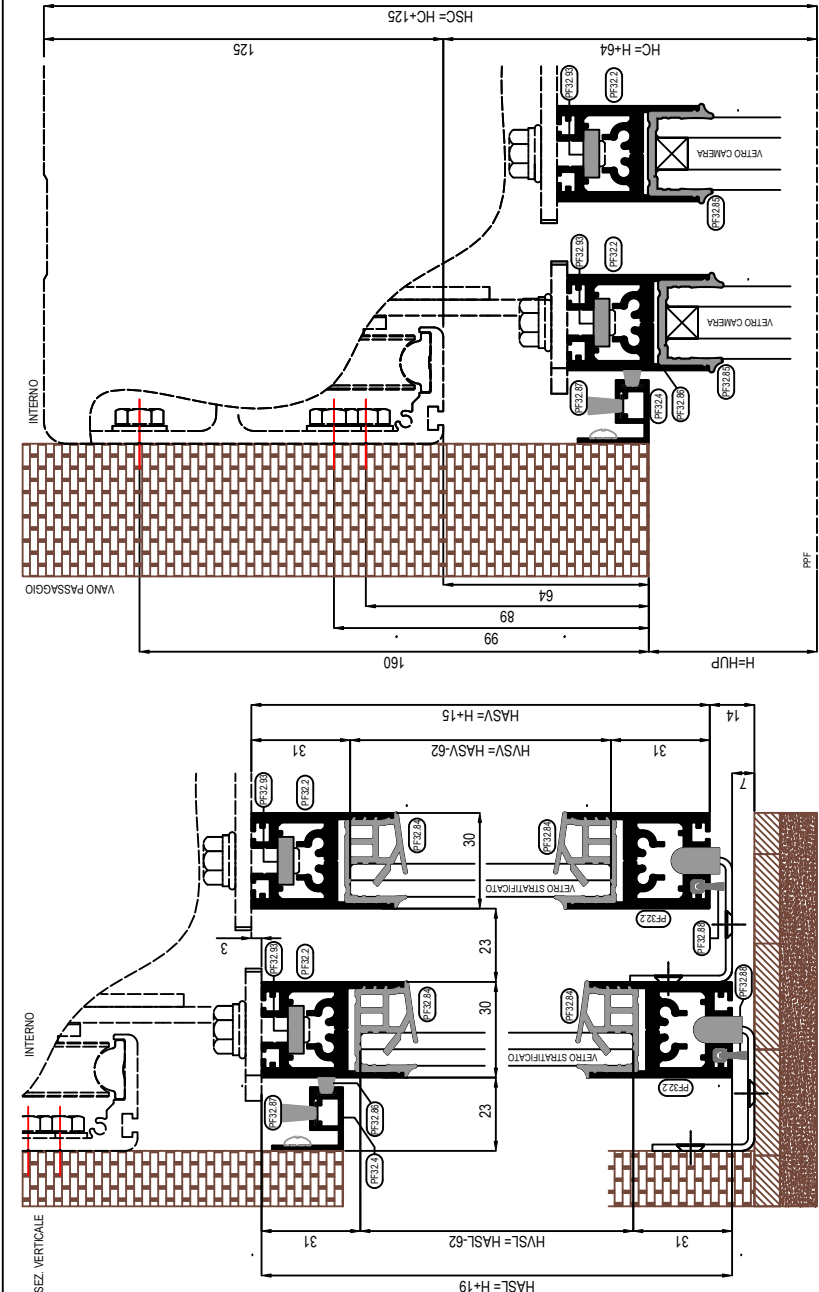

CODICE	DESCRIZIONE	Q.TA'	APPLICAZIONE
PF32.90	PATTINO ANTA SCOR. SX	2	SCORREVOLI
PF32.91	SQUADRETTHE INTERNE	8	FISSA+SCOR.
PF32.93	KIT FISSAGGIO CARRELLI	2	SCORREVOLI
PF32.94	KIT VITI FISSAGGIO ANTA	2	FISSA+SCOR.
ACCESSORI			

CODICE	DESCRIZIONE	Q.TA'	FORMULE	TAV. LAVORAZIONE	APPLICAZIONE
PF32.1	MONTANTE	2	HASL	M30-01+M30-02	SCOR. LENTA
PF32.1	MONTANTE	2	HASV	M30-01+M30-02	SCOR. VELOCE
PF32.2	TRAVERSO	4	LASL-76	-	SCORREVOLE
PF32.3	LABIRINTO	2	HASL	M30-03+M30-07	SCOR. LENTA
PF32.3	LABIRINTO	1	HASV	M30-03+M30-07	SCOR. VELOCE
PF32.5	SOTTO TRAVERSO	1	HASV+14	-	BATTUTA
PF32.4	CORNICE	1	H	-	FINITURA VANO
PF32.4	CORNICE	1	L+10	-	FINITURA VANO
PF32.81	GURANIZIONE DI BATTUTA	1	(HASVx2)+14	M30-06	SCOR.+BATTUTA
PF32.84	GUAR. VETRI STRATIFICATI	1	((HVSL+LVSL)+(HVSV+LVSV)+12)x2	-	SCORREVOLE
PF32.85	GUAR. VETRI CAMERA	1	((HVSL+LVSL)+(HVSV+LVSV)+12)x2	-	SCORREVOLE
PF32.86	SPAZ. MORBIDO H6mm	1	(HASLx2)+HASCV+H+(LUP+10)	-	VANO+SCOR.
PF32.87	SPAZ. MORBIDO H11mm	1	(HASLx2)+HASCV+H+(LUP+10)	-	VANO+SCOR.
PF32.88	SPAZ. RIGIDO H10mm	1	LASL-17	-	SCOR. LENTA
PF32.88	SPAZ. RIGIDO H10mm	1	LASV-17	-	SCOR. VELOCE

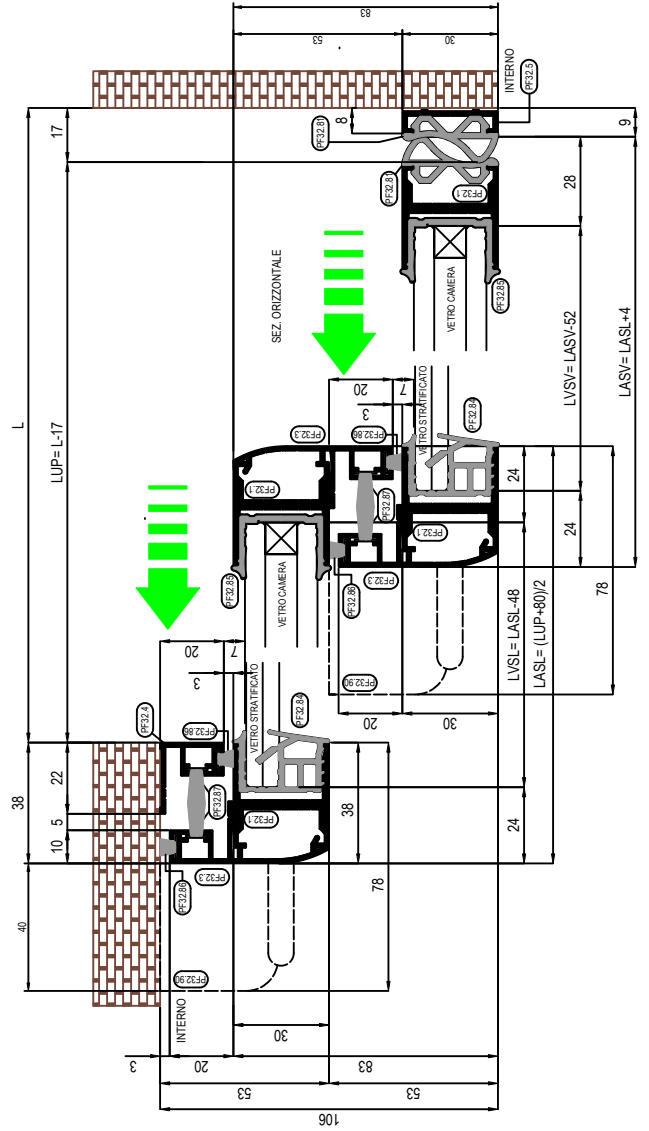
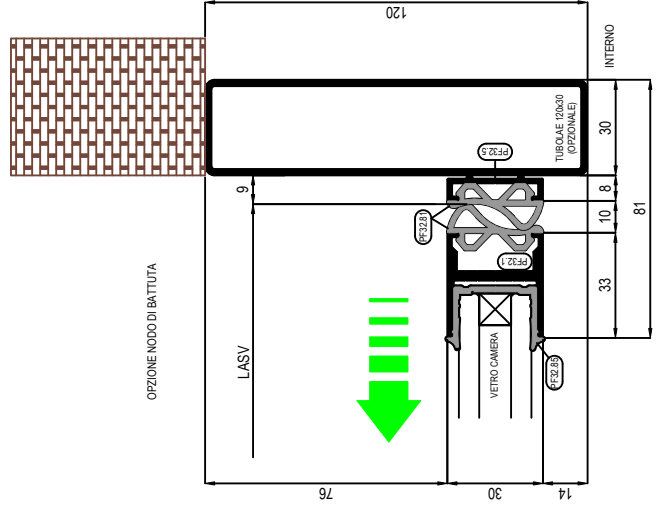
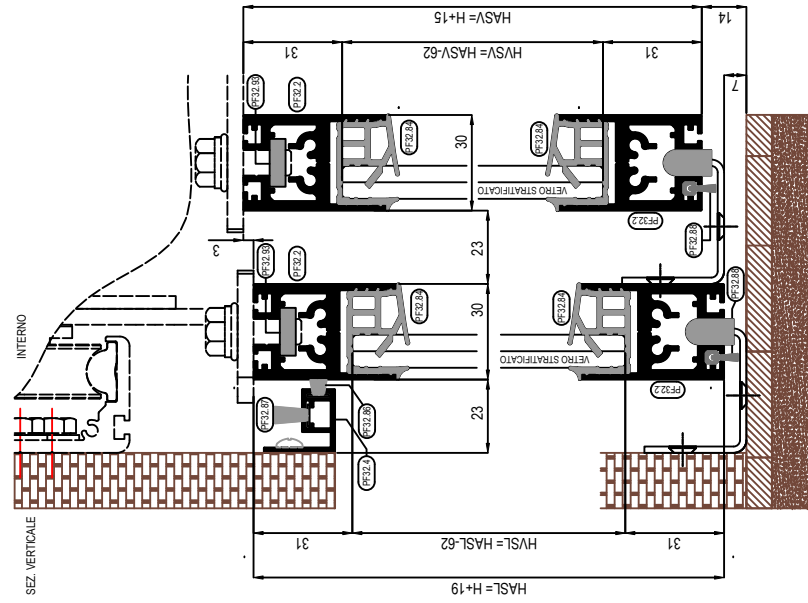
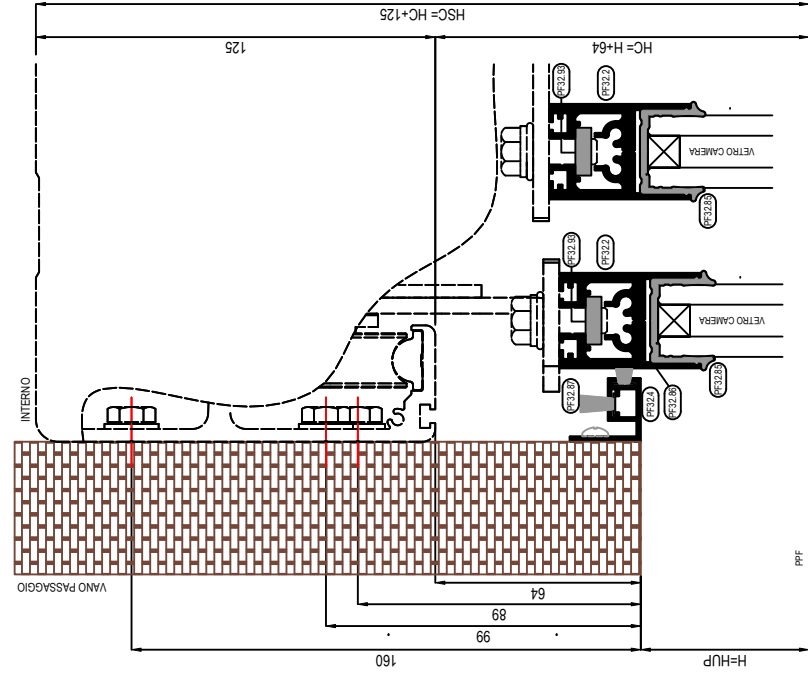



CODICE	DESCRIZIONE	TAV. LAVORAZIONE	FORMULE	Q.TA'	APPLICAZIONE
PF32.89	PATTINO ANTA SCOR. SX			2	SCORREVOLI
PF32.91	SQUADRETTA INTERNE	M30-01+M30-02		8	FISSA+SCOR.
PF32.93	KIT FISSAGGIO CARRELLI			2	SCORREVOLI
PF32.94	KIT VITI FISSAGGIO ANTA			2	FISSA+SCOR.
ACCESSORI					

PROFILI ALLUMINIO					
CODICE	DESCRIZIONE	Q.TA'	FORMULE	TAV. LAVORAZIONE	APPLICAZIONE
PF32.1	MONTANTE	2	HASL	M30-01+M30-02	SCOR. LENTA
PF32.1	MONTANTE	2	HASV	M30-01+M30-02	SCOR. VELOCE
PF32.2	TRAVERSO	4	LASL-76	-	SCORREVOLE
PF32.3	LABIRINTO	2	HASL	M30-03+M30-07	SCOR. LENTA
PF32.3	LABIRINTO	1	HASV	M30-03+M30-07	SCOR. VELOCE
PF32.5	SOTTO TRAVERSO	1	HASV+14	-	BATTUTA
PF32.4	CORNICE	1	H	-	FINITURA VANO
PF32.4	CORNICE	1	L+10	-	FINITURA VANO

GUARNIZIONI					
CODICE	DESCRIZIONE	Q.TA'	FORMULE	TAV. LAVORAZIONE	APPLICAZIONE
PF32.81	GURANIZIONE DI BATTUTA	1	(HASVx2)+14	M30-06	SCOR.+BATTUTA
PF32.84	GUAR. VETRI STRATIFICATI	1	((HVSL+LVSL)+(HVSV+LVSV)+12)x2		SCORREVOLE
PF32.85	GUAR. VETRI CAMERA	1	((HVSL+LVSL)+(HVSV+LVSV)+12)x2		SCORREVOLE
PF32.86	SPAZ. MORBIDO H6mm	1	(HASLx2)+HASCV+H+(LUP+10)		VANO+SCOR.
PF32.87	SPAZ. MORBIDO H11mm	1	(HASLx2)+HASCV+H+(LUP+10)		VANO+SCOR.
PF32.88	SPAZ. RIGIDO H10mm	1	LASL-17		SCOR. LENTA
PF32.88	SPAZ. RIGIDO H10mm	1	LASV-17		SCOR. VELOCE

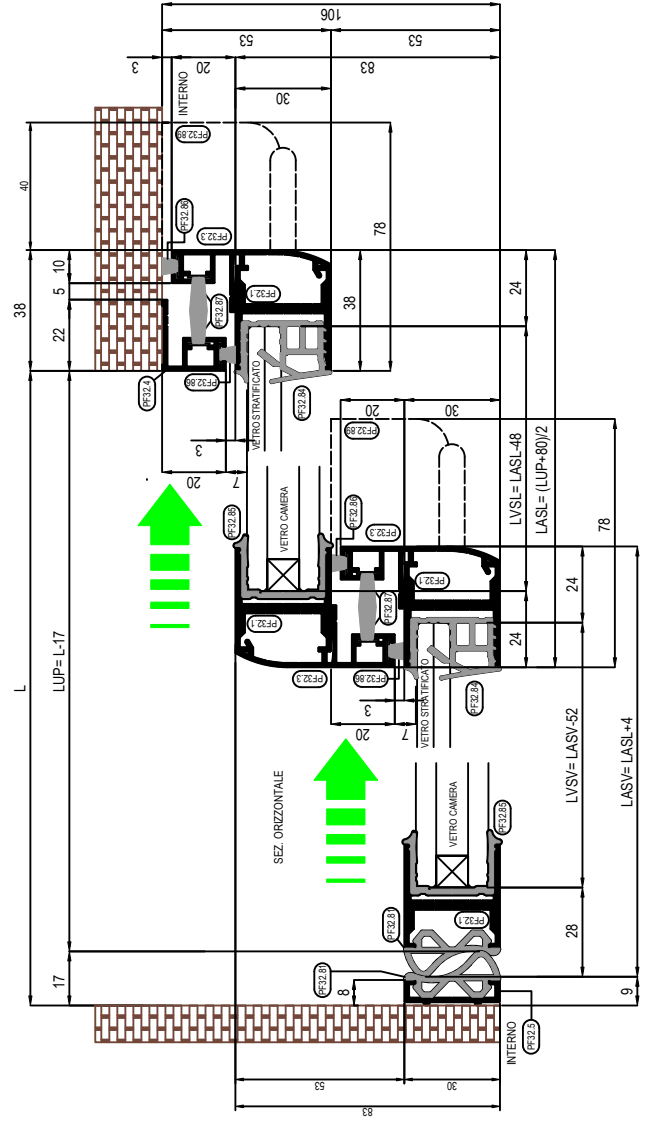
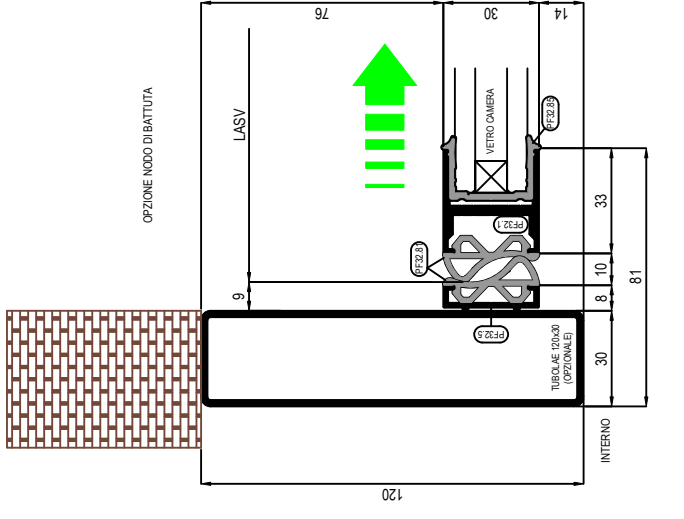
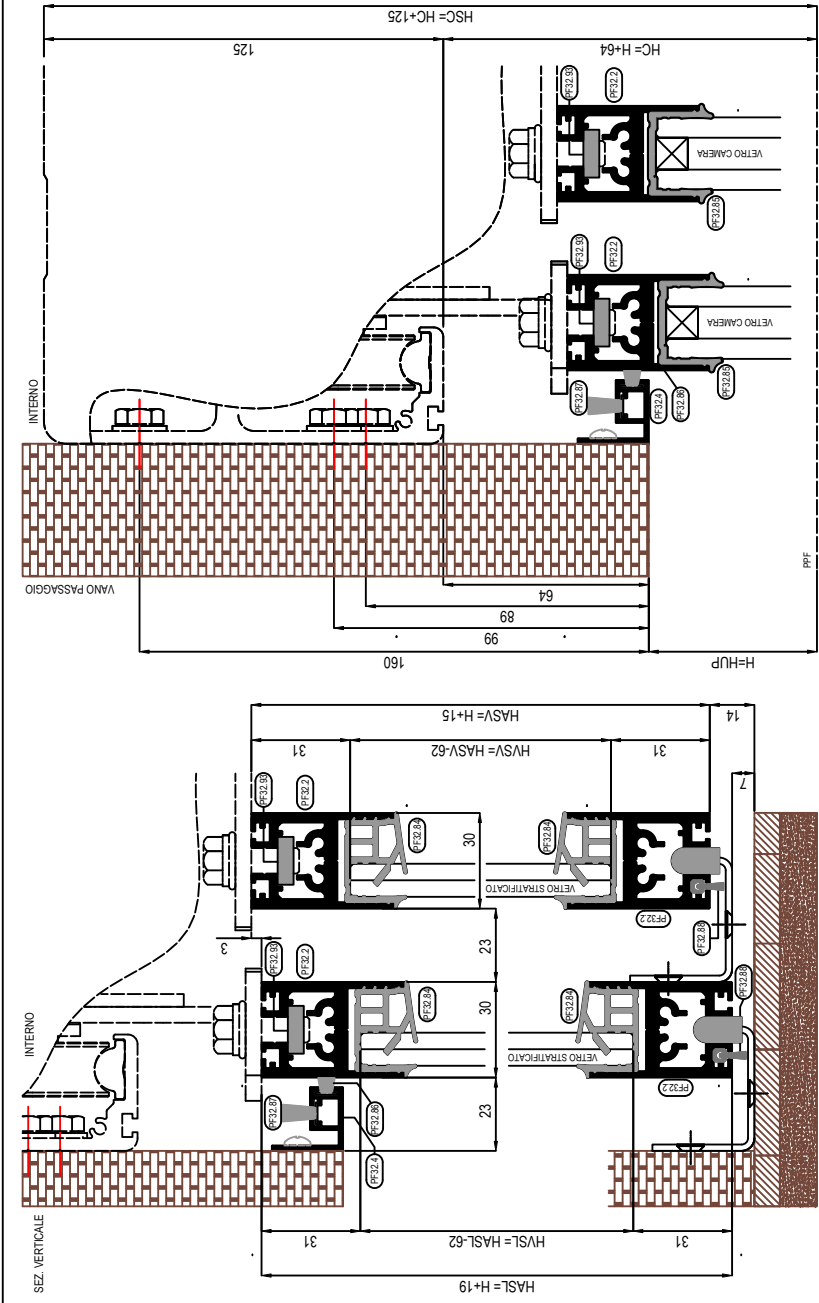

ASSEMBLATO

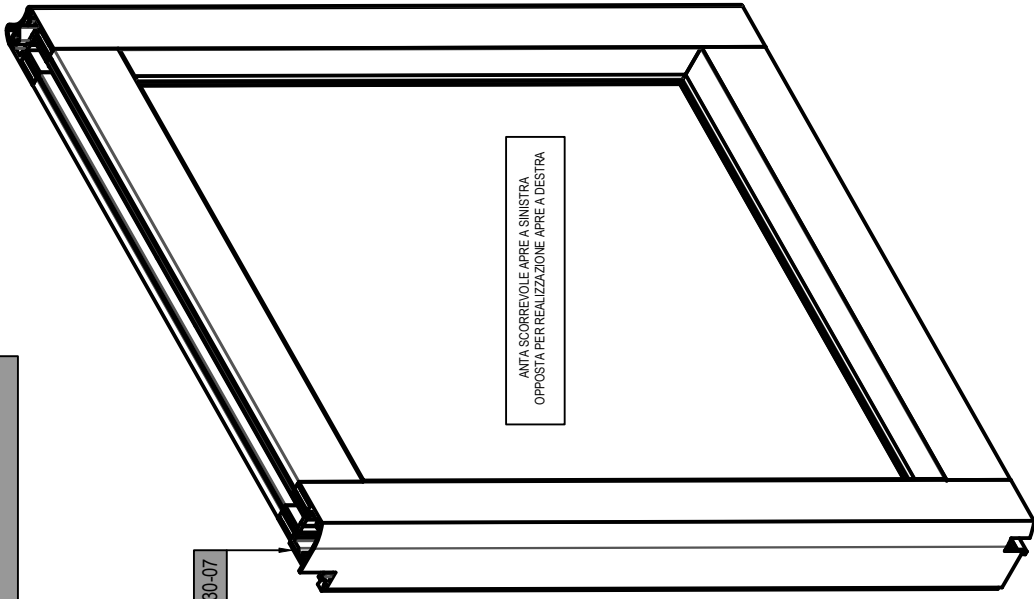

ANTA SCORREVOLE APRE A SINISTRA
OPPOSTA PER REALIZZAZIONE APRE A DESTRA

LAV. M30-07

CONSIGLIATO INCOLLARE
CON COLLA CIANACRILICA

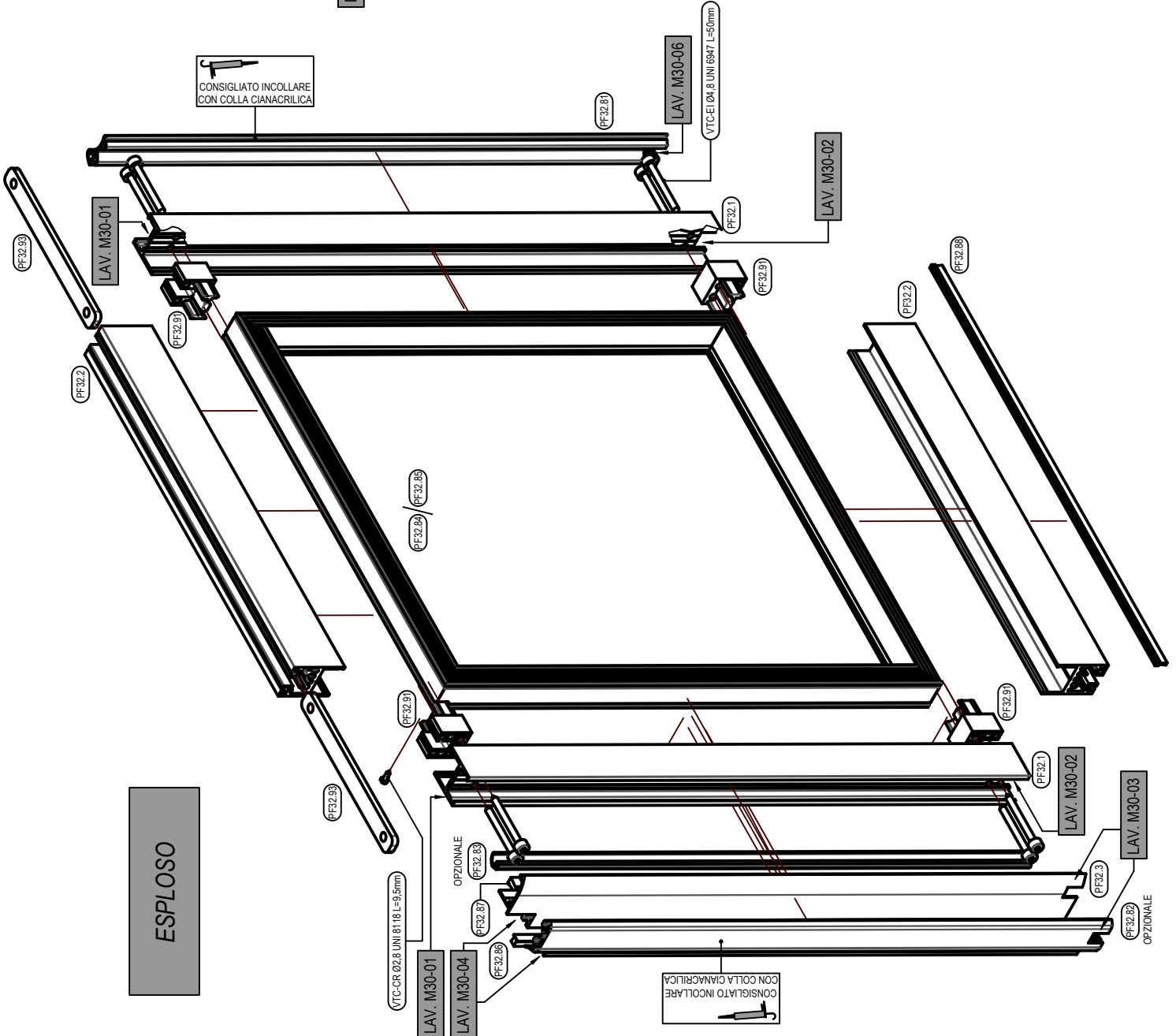

ESPLOSO

(VTC-CR 023 UNI 8118 L=9,5mm)

LAV. M30-01

LAV. M30-04

(PF32.87)

(PF32.88)

OPZIONALE

(PF32.89)

(PF32.90)

CONSIGLIATO INCOLLARE
CON COLLA CIANACRILICA

(PF32.81)

LAV. M30-06

(VTC-EI 004.8 UNI 6947 L=50mm)

(PF32.1)

LAV. M30-02

(PF32.91)

(PF32.2)

(PF32.88)

LAV. M30-02

(PF32.1)

LAV. M30-03

(PF32.3)

OPZIONALE

(PF32.82)

ASSEMBLATO

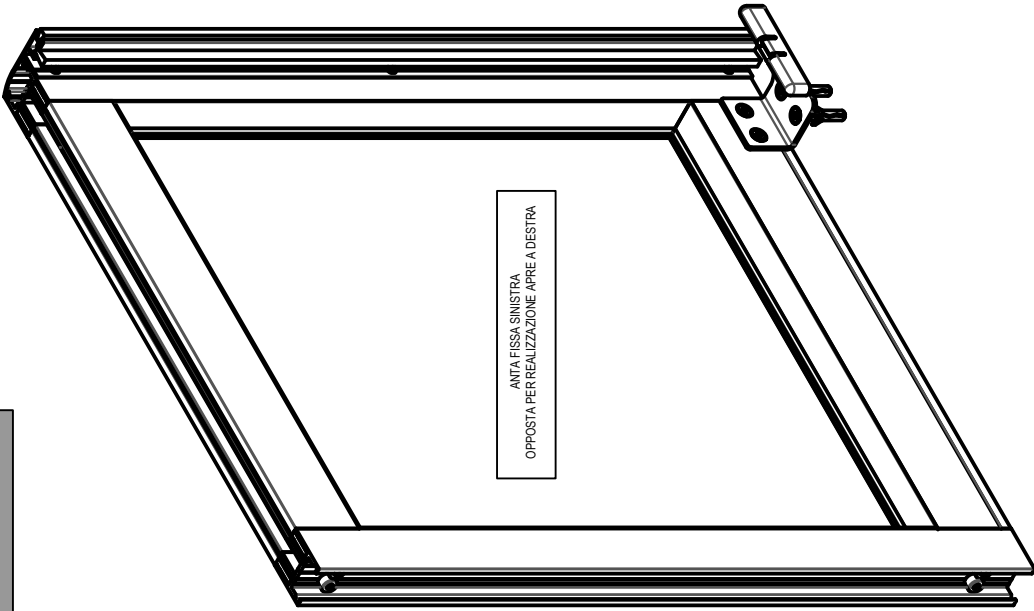

ANTA FISSA SINISTRA
OPPOSTA PER REALIZZAZIONE APRE A DESTRA

ESPLOSO

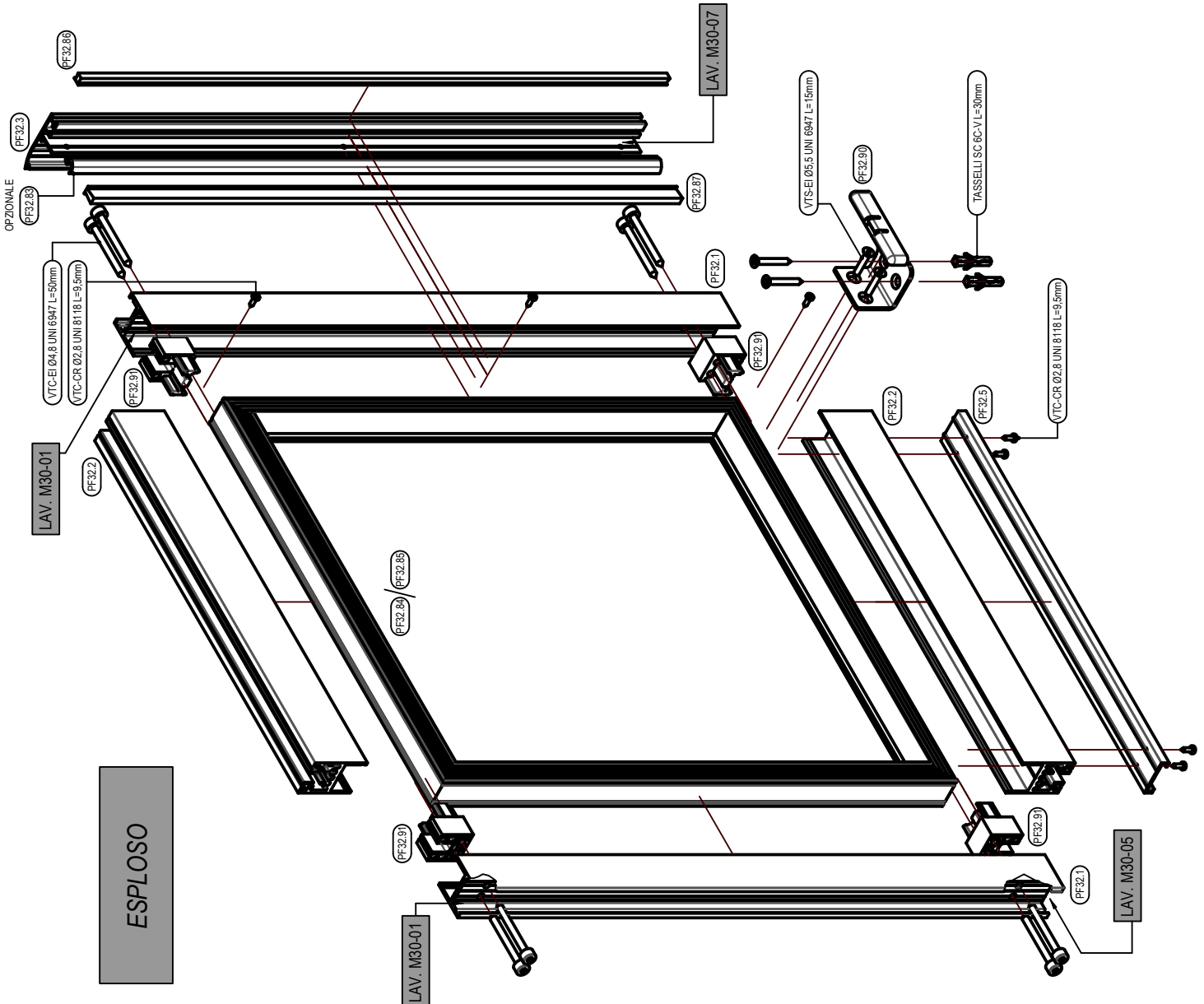

ASSEMBLATO

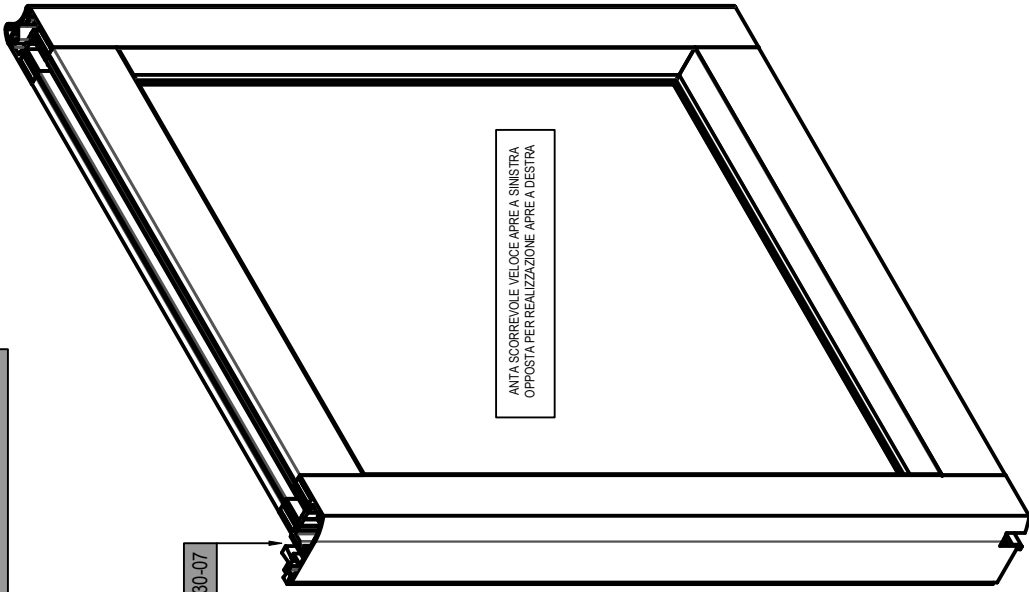

ANTA SCORREVOLE VELOCE APRE A SINISTRA
OPPOSTA PER REALIZZAZIONE APRE A DESTRA

LAV. M30-07

CONSIGLIATO INCOLLARE
CON COLLA CIANACRILICA

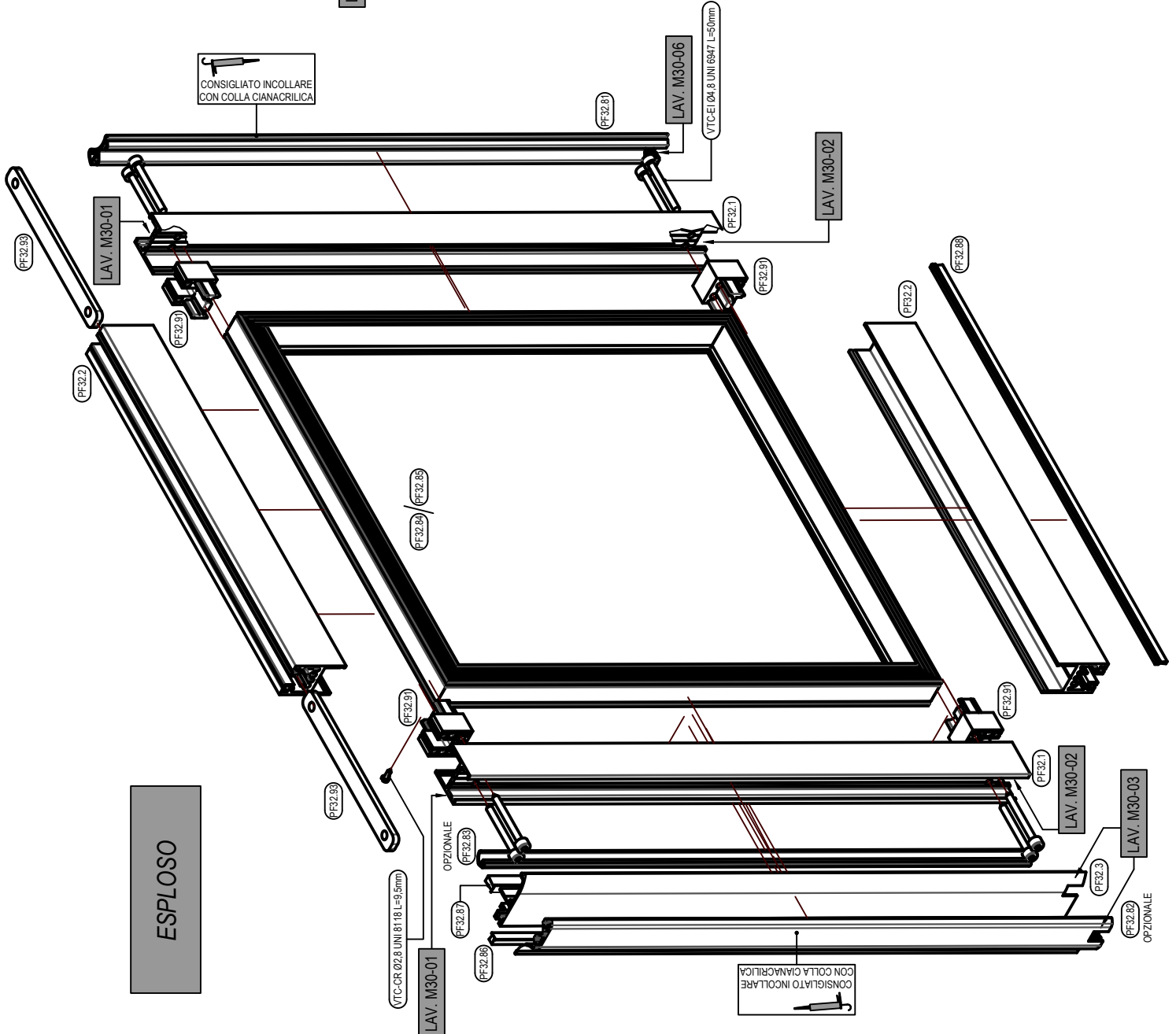

ESPLOSO

LAV. M30-01

(VTC-CR 024 UNI 8118 L=95mm)

OPZIONALE

(PF32.87)

(PF32.86)

CONSIGLIATO INCOLLARE
CON COLLA CIANACRILICA

LAV. M30-02

LAV. M30-03

OPZIONALE

(PF32.83)

LAV. M30-01

(PF32.2)

(PF32.91)

(PF32.85) / (PF32.86)

(PF32.91)

(PF32.93)

(PF32.81)

LAV. M30-06

(VTC-EI 004.8 UNI 6947 L=50mm)

(PF32.1)

LAV. M30-02

(PF32.91)

(PF32.2)

(PF32.88)

(PF32.91)

(PF32.1)

(PF32.3)

(PF32.82)

ASSEMBLATO

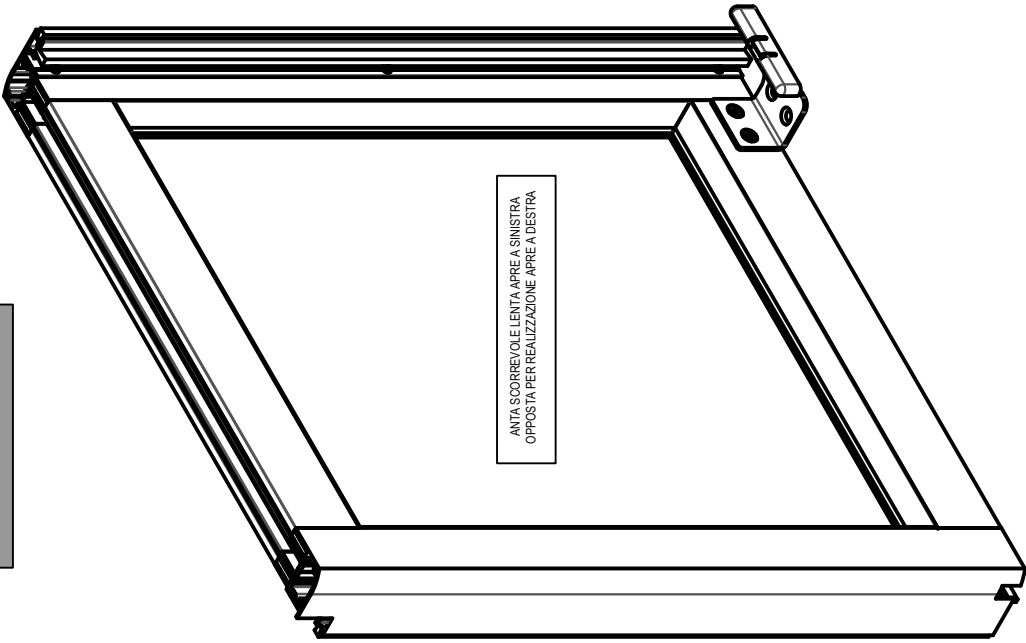

ANTA SCORREVOLE LENTA APRE A SINISTRA
OPPOSTA PER REALIZZAZIONE APRE A DESTRA

ESPLOSO

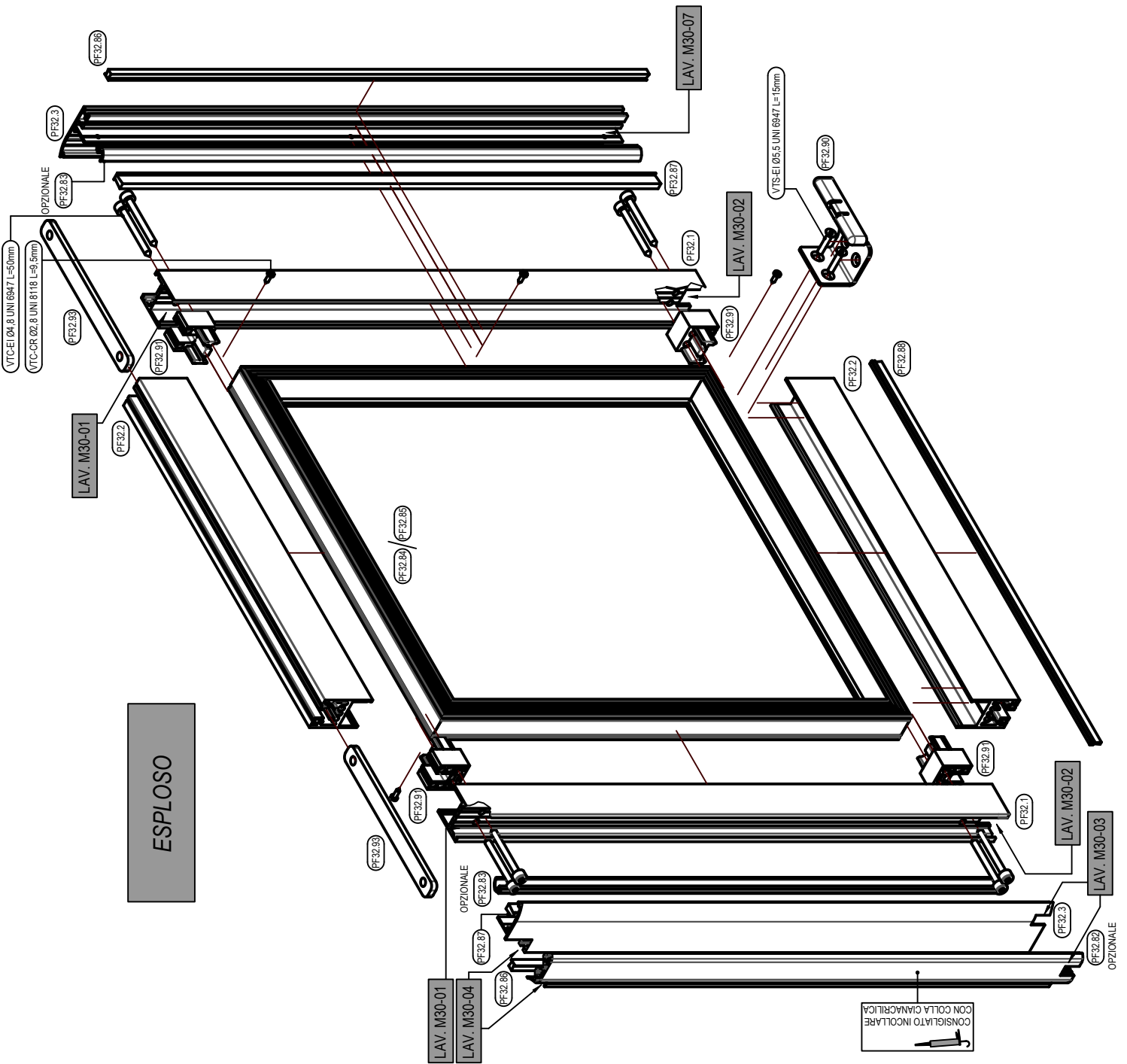

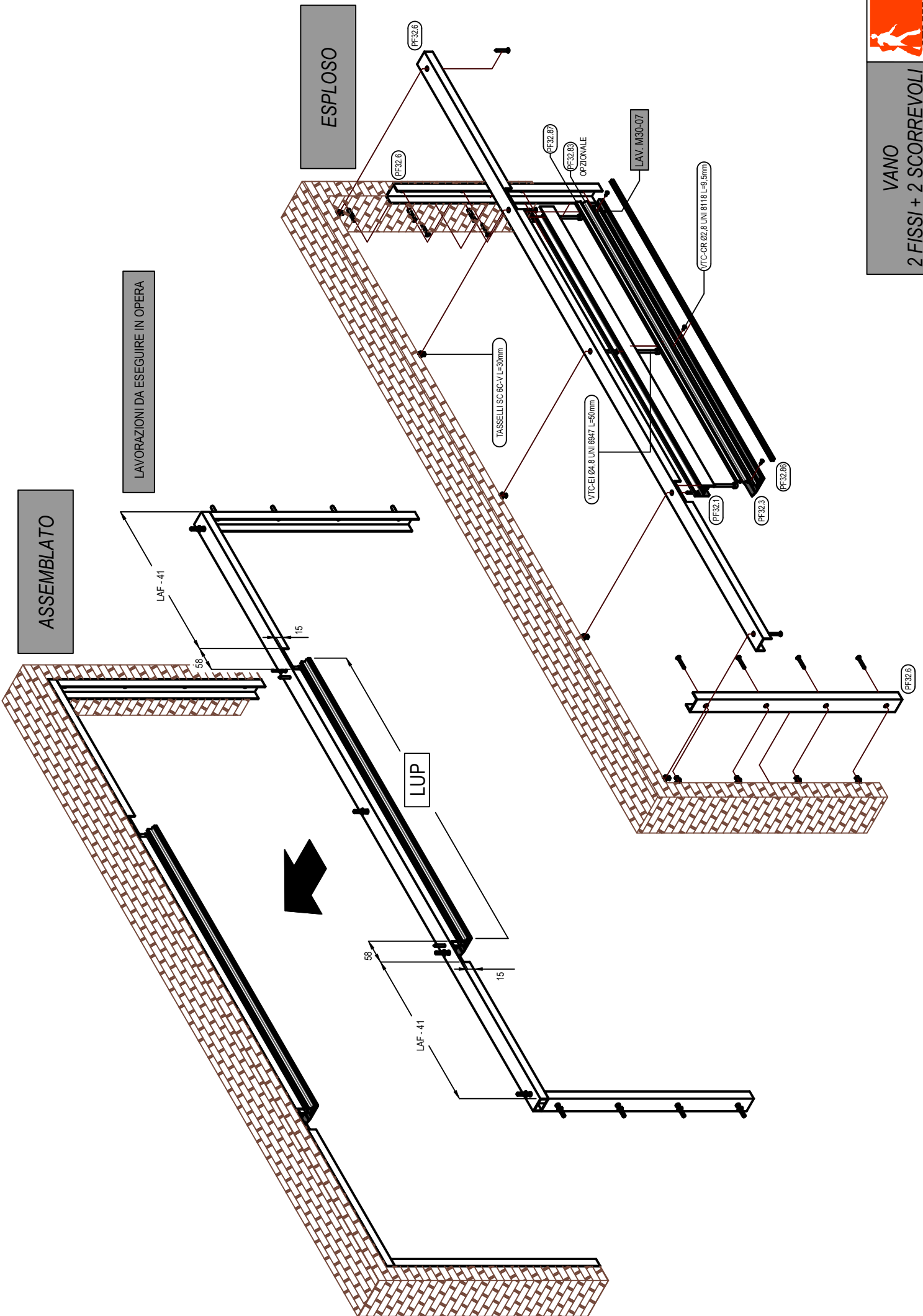

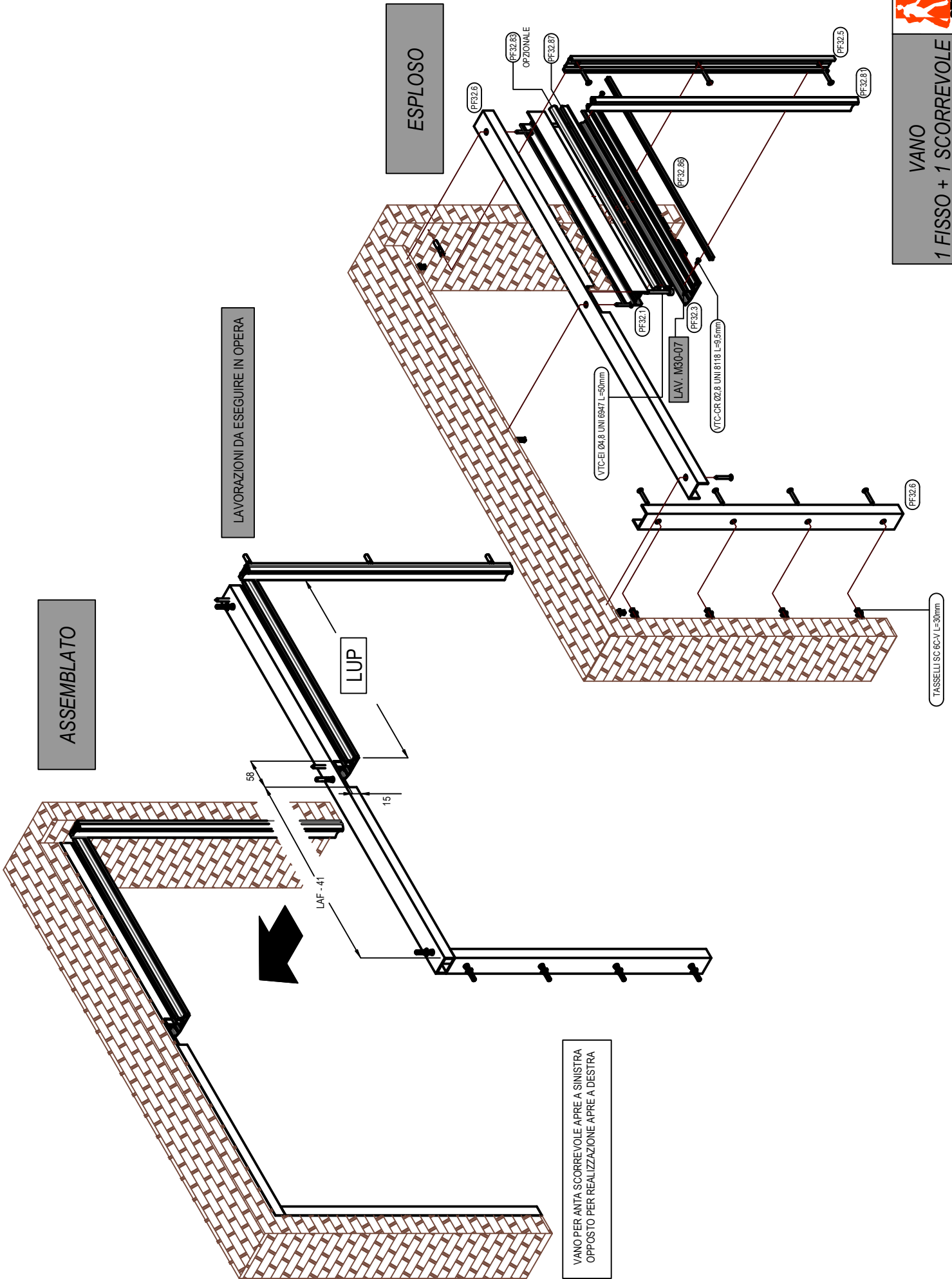

ESPLOSO

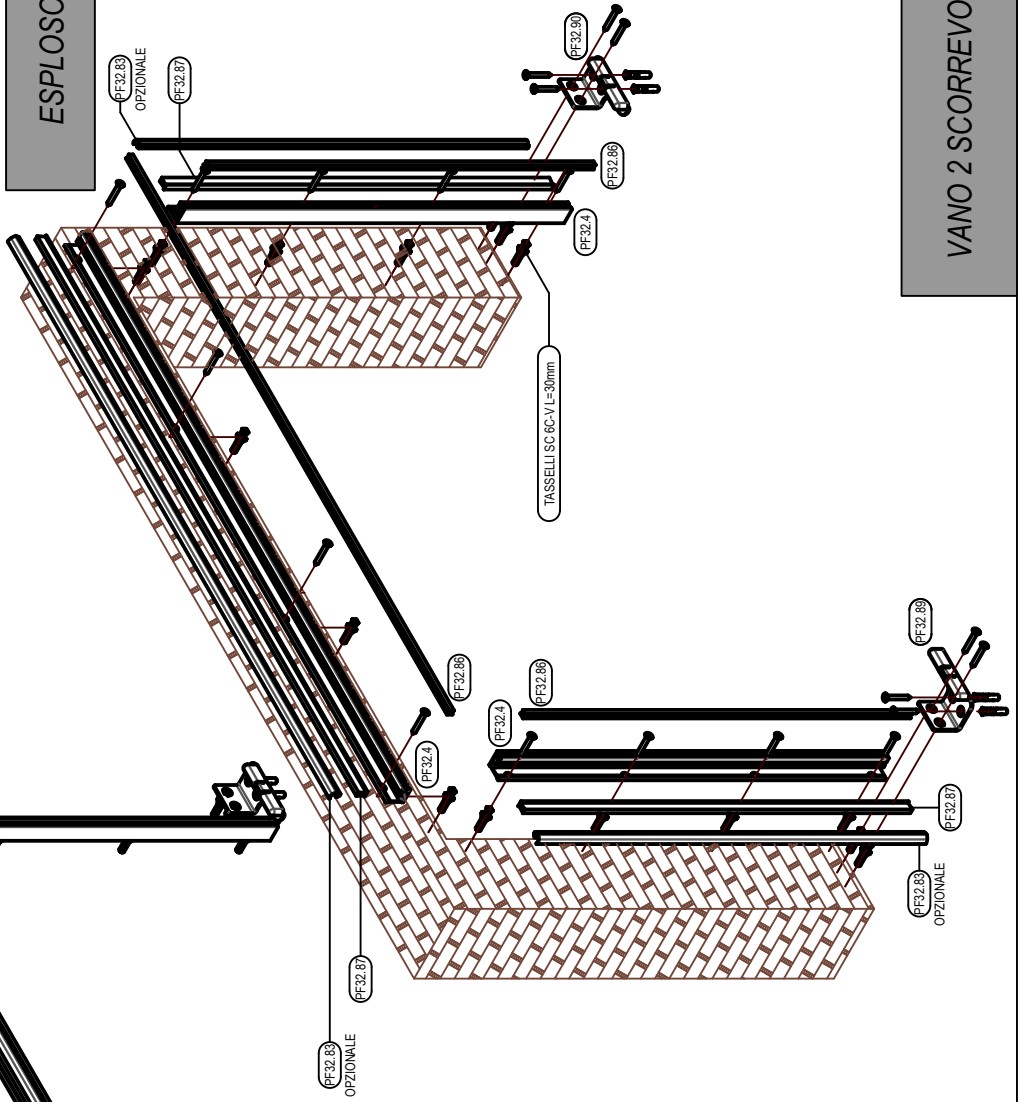

ASSEMBLATO

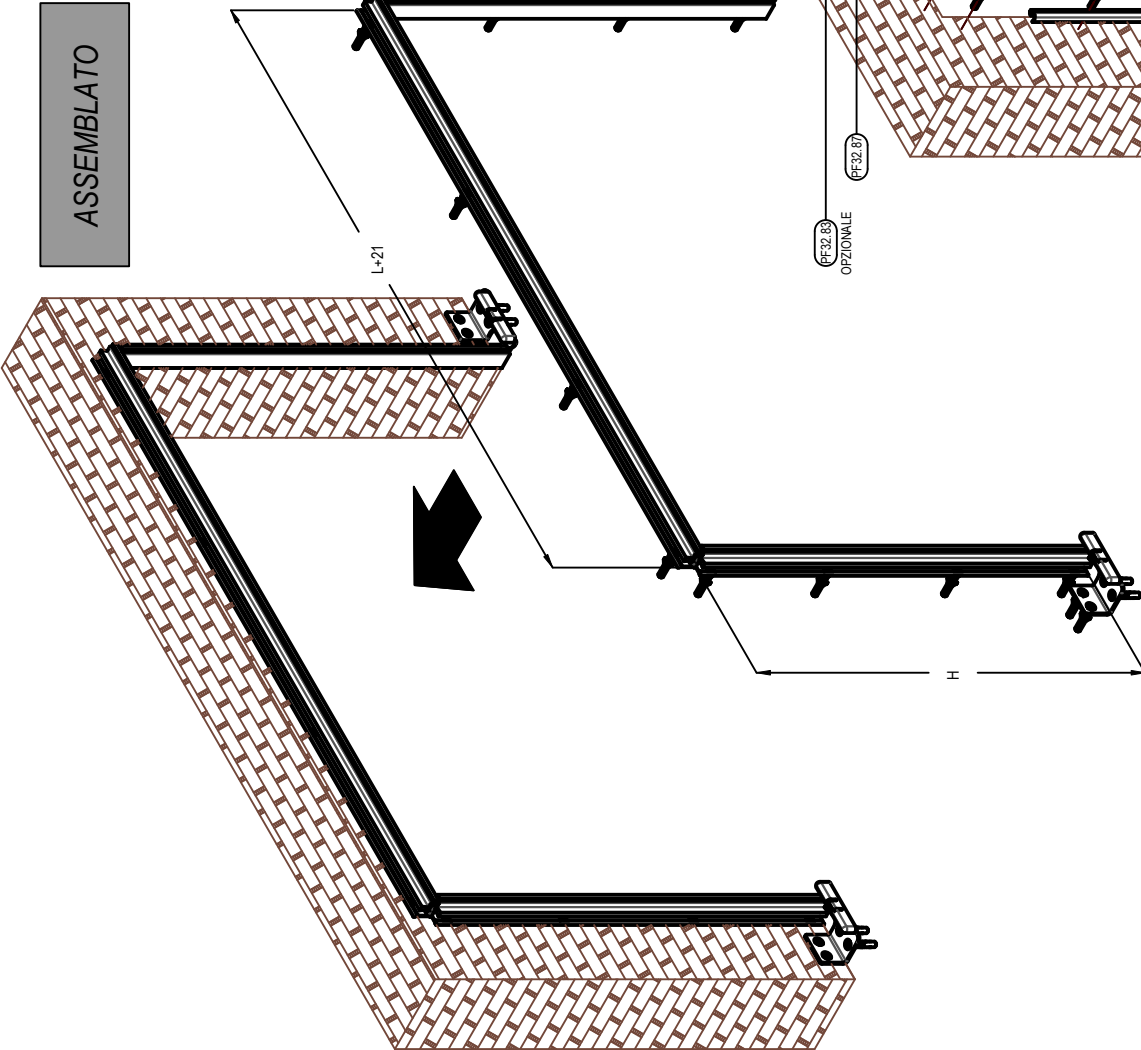

ESPLOSO

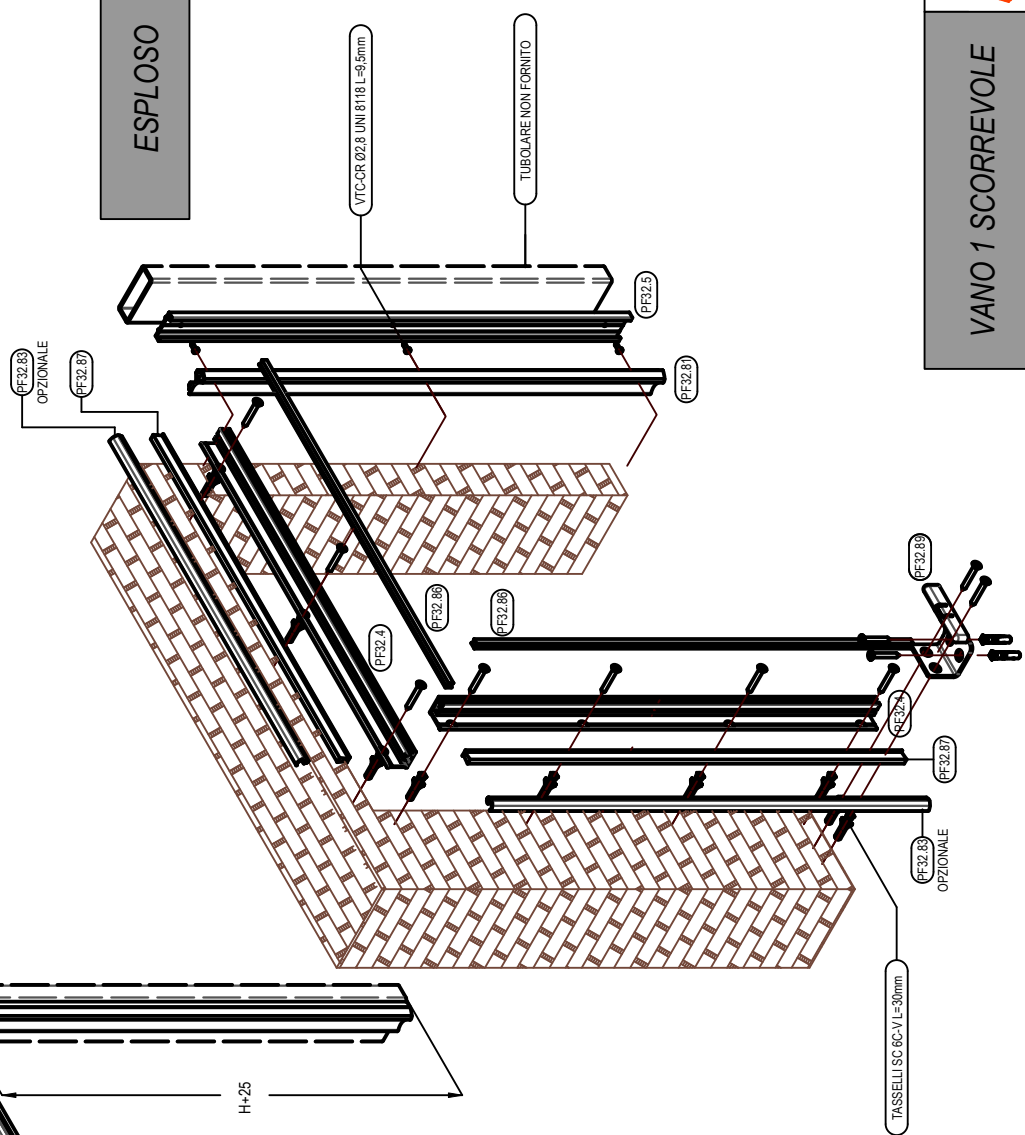

ASSEMBLATO

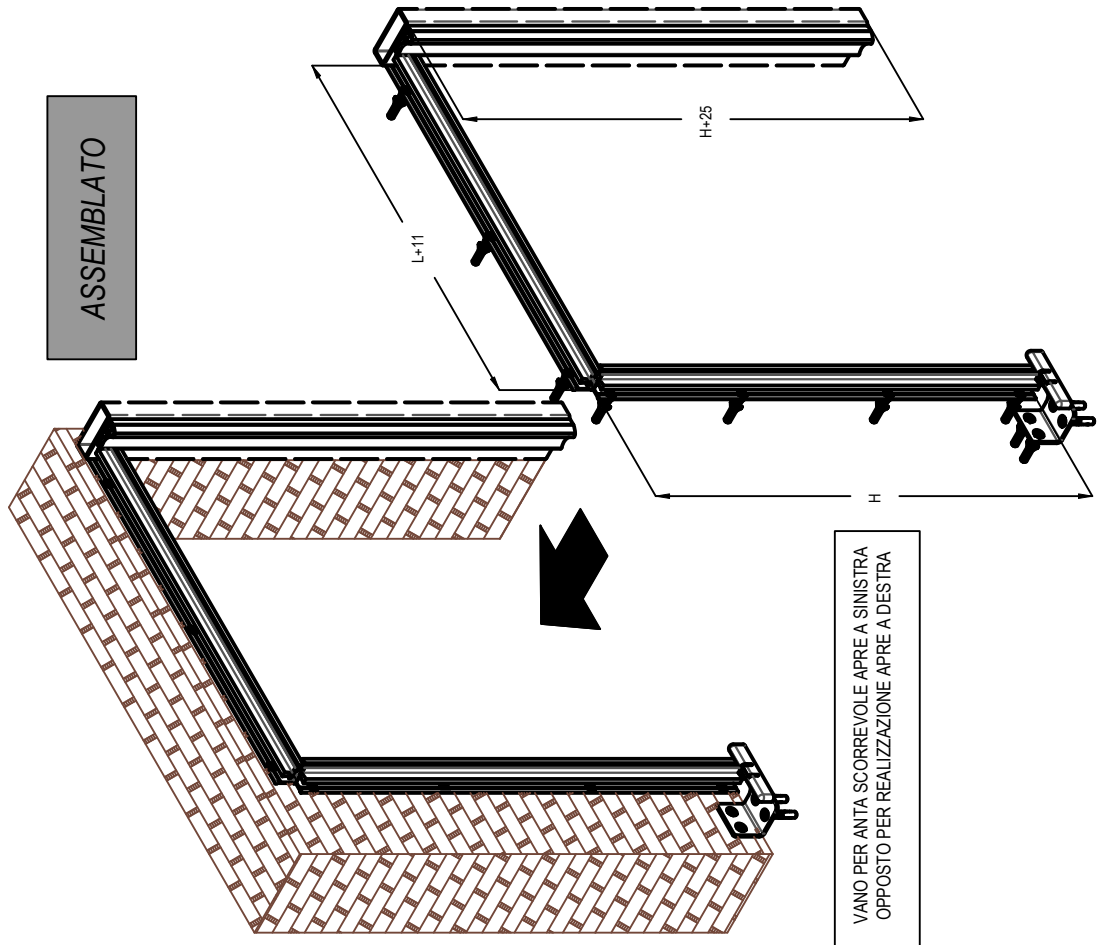

VANO PER ANTA SCORREVOLE APRE A SINISTRA
OPPOSTO PER REALIZZAZIONE APRE A DESTRA

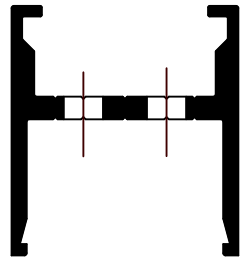
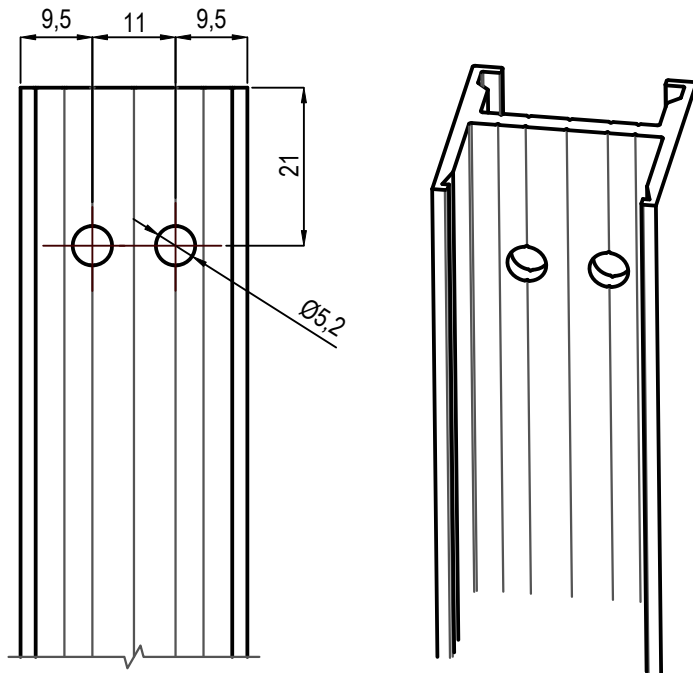

LAV. M30-01

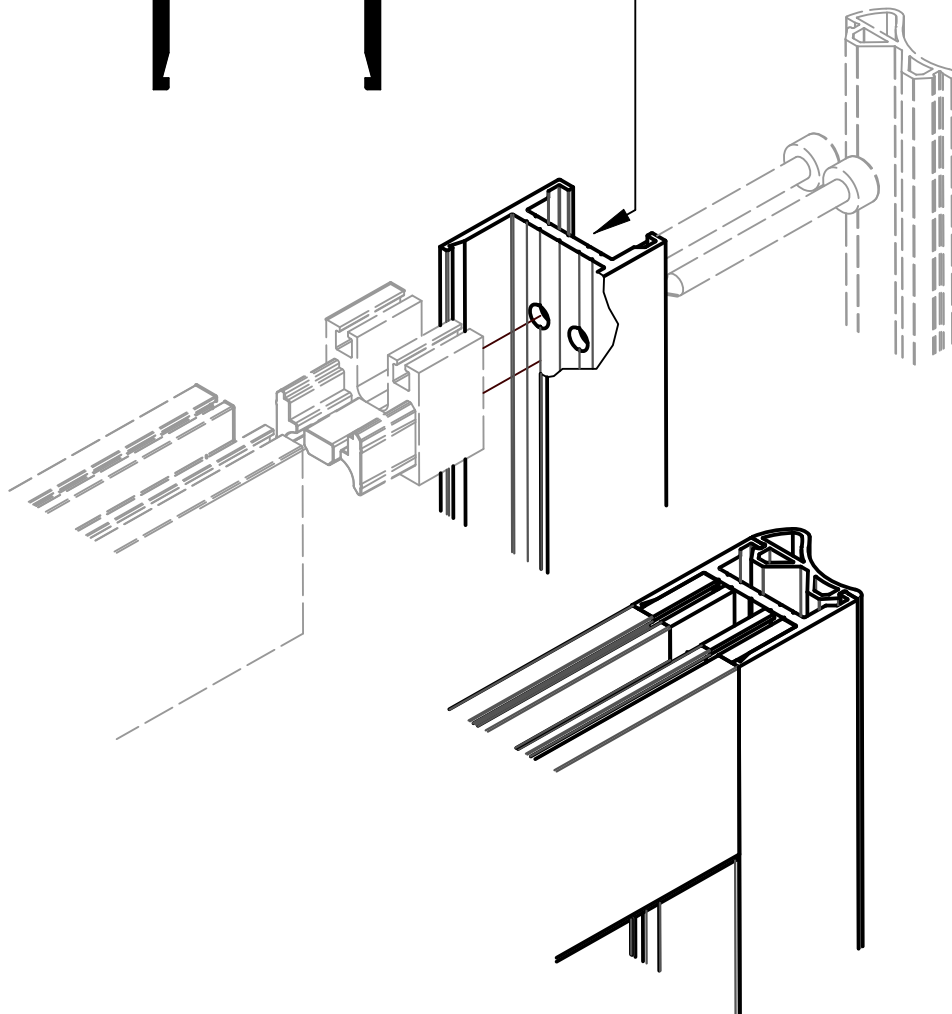

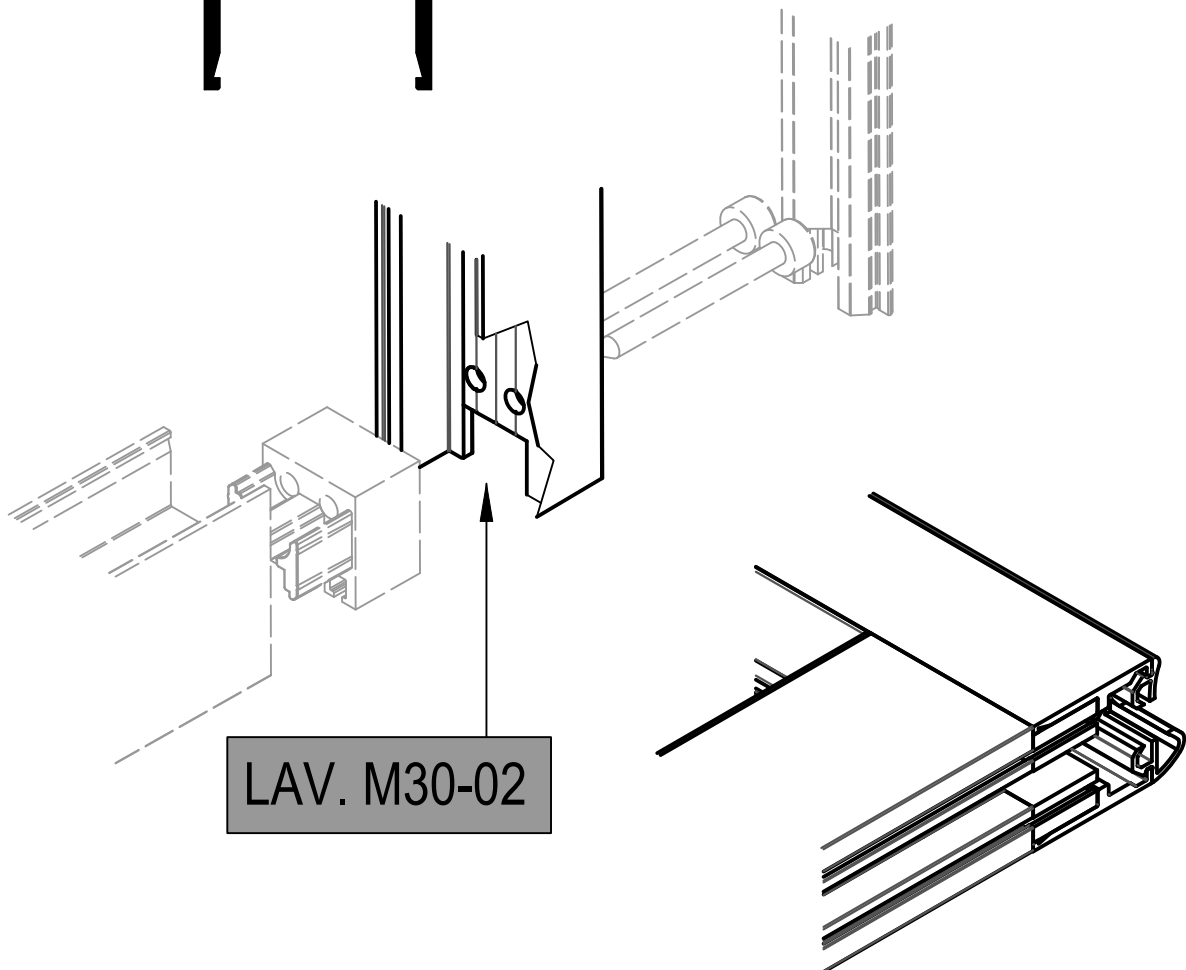
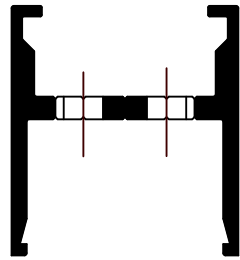
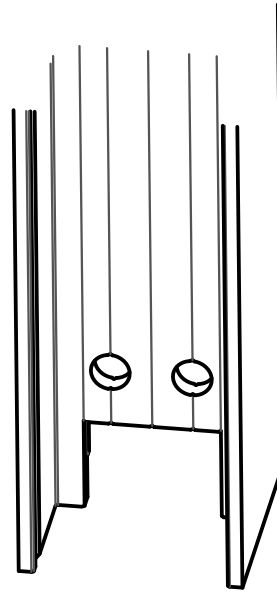
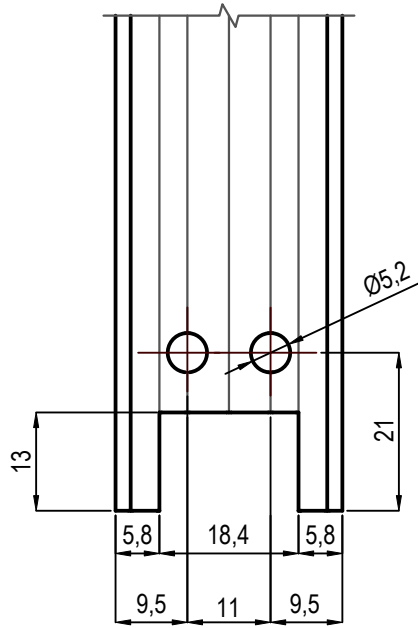

LAV. M30-02

VALIDO PER ANTA SCORREVOLE APRE A SINISTRA,
ESEGUIRE LAVORAZIONE OPPOSTA PER ANTA APRE A DESTRA

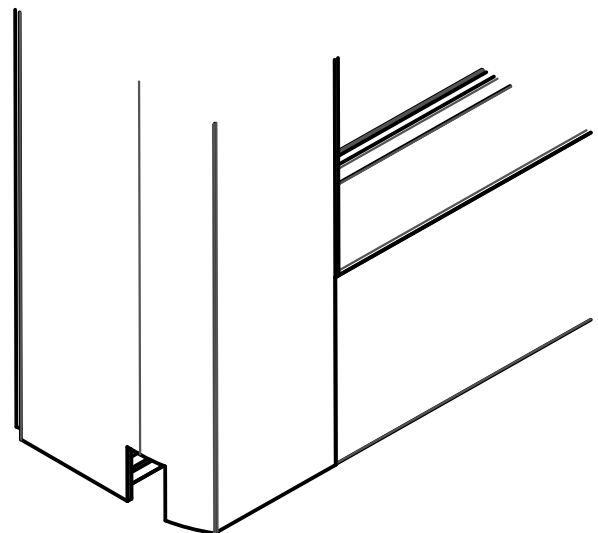
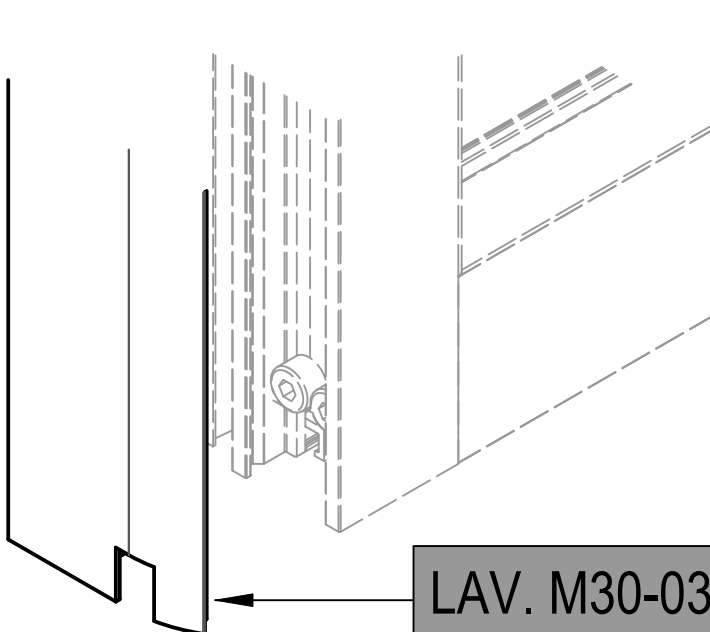
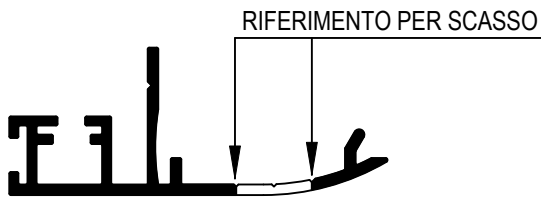
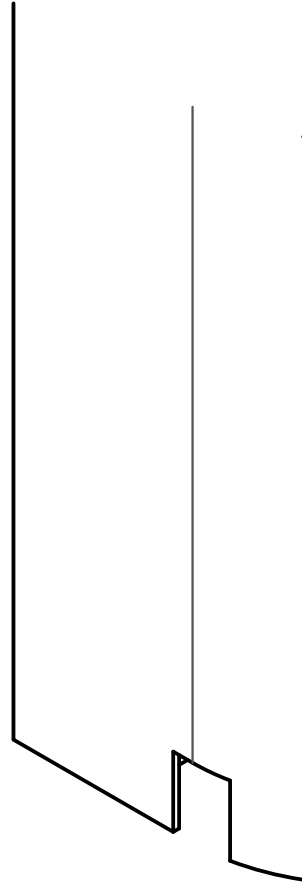
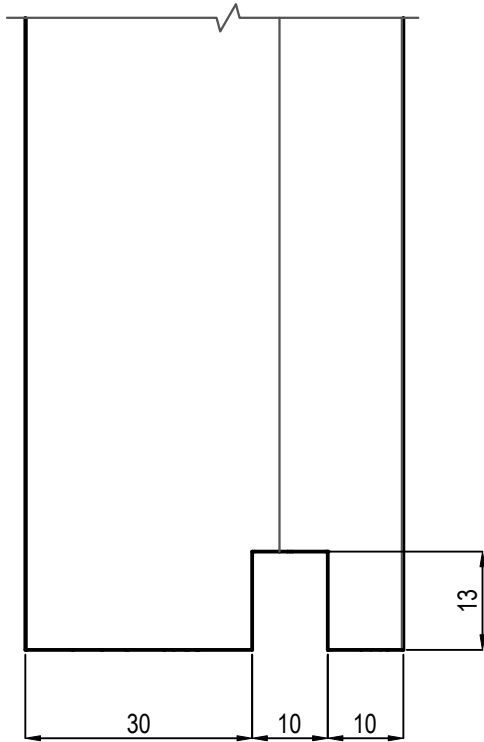

LAV. M30-03

VALIDO PER ANTA SCORREVOLE APRE A SINISTRA,
ESEGUIRE LAVORAZIONE OPPOSTA PER ANTA APRE A DESTRA

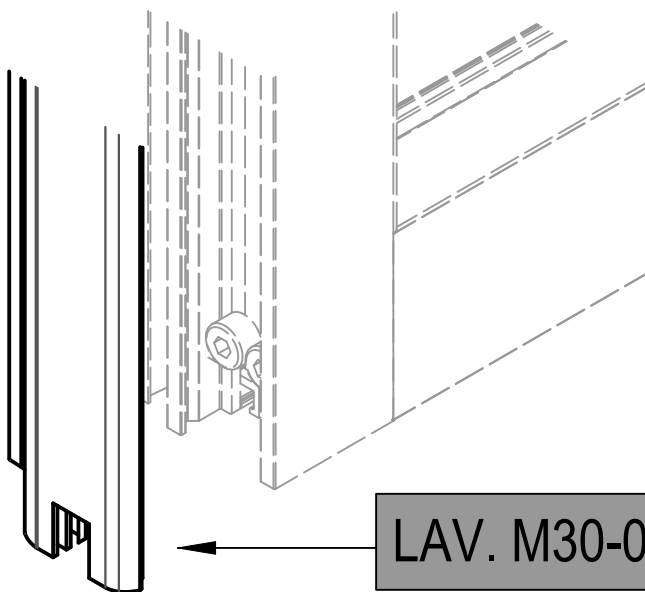
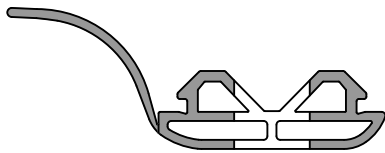
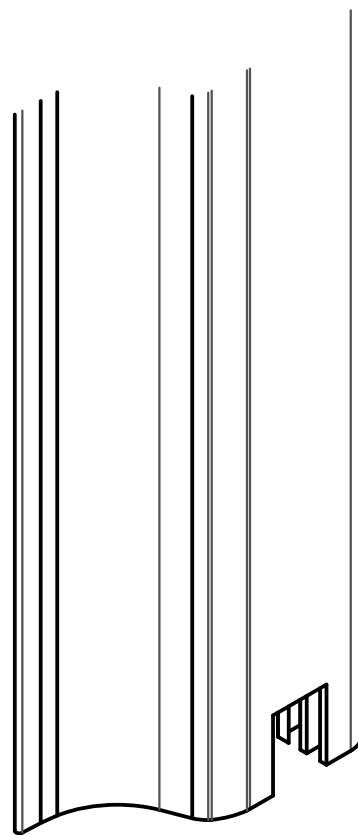
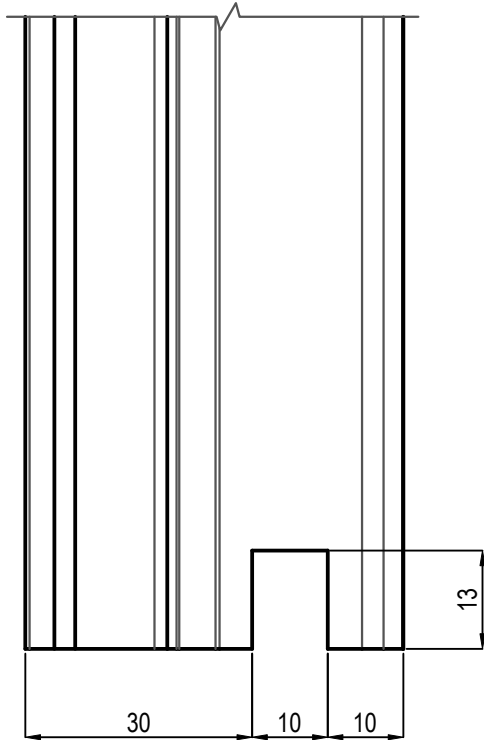

LAV. M30-03

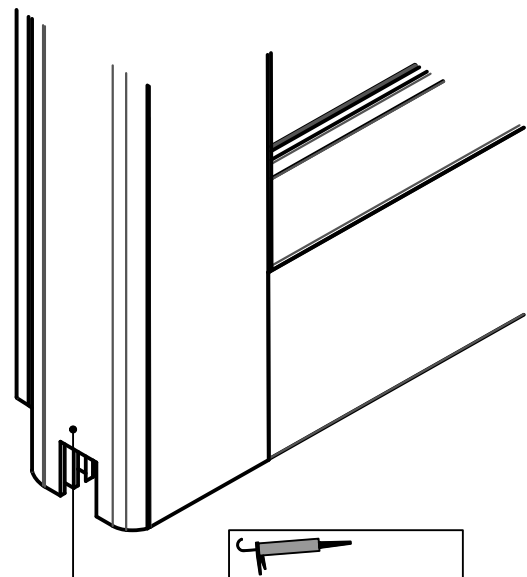

CONSIGLIATO INCOLLARE
CON COLLA CIANACRILICA

VALIDO PER ANTA SCORREVOLE APRE A SINISTRA,
ESEGUIRE LAVORAZIONE OPPOSTA PER ANTA APRE A DESTRA

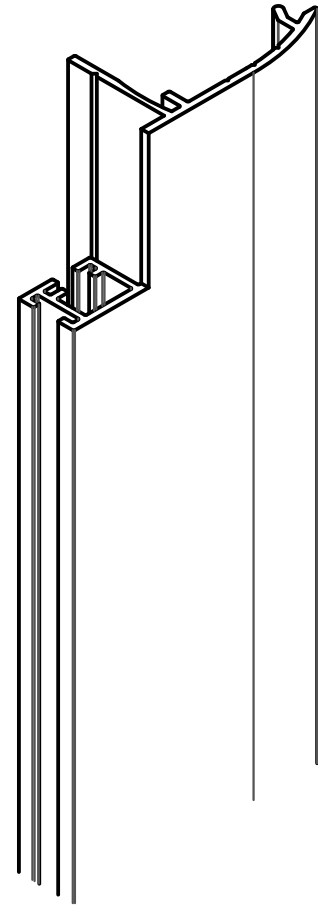
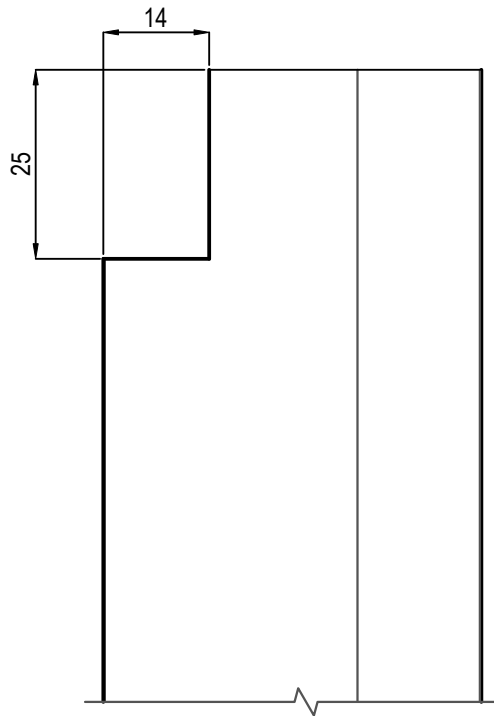

LAV. M30-04

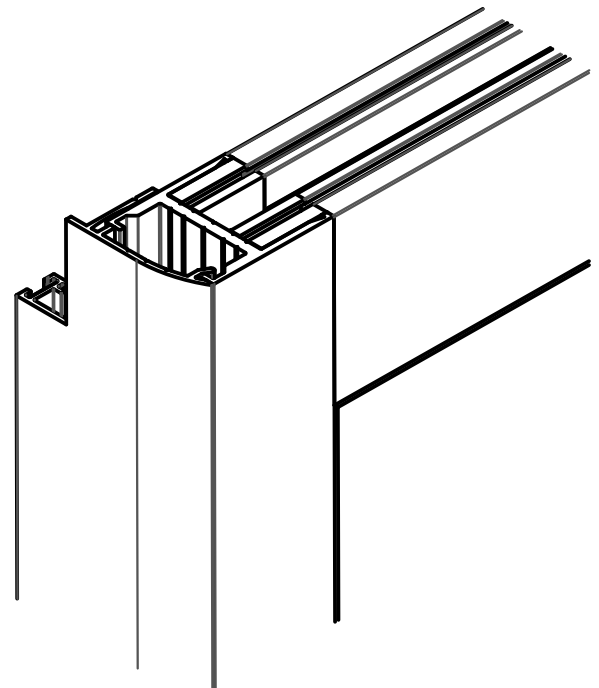
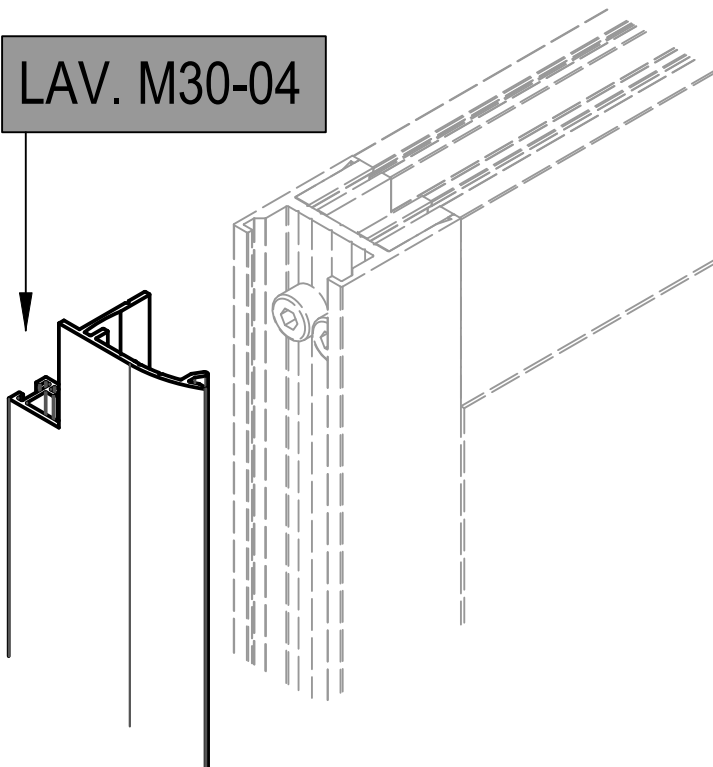



LAV. M30-04 SCALA 1:1

SU GUARNIZIONE
LABIRINTO PF32.82

VALIDO PER ANTA SCORREVOLE APRE A SINISTRA,
ESEGUIRE LAVORAZIONE OPPOSTA PER ANTA APRE A DESTRA

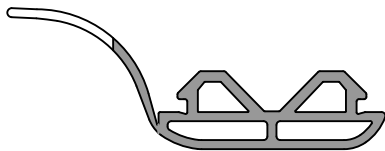
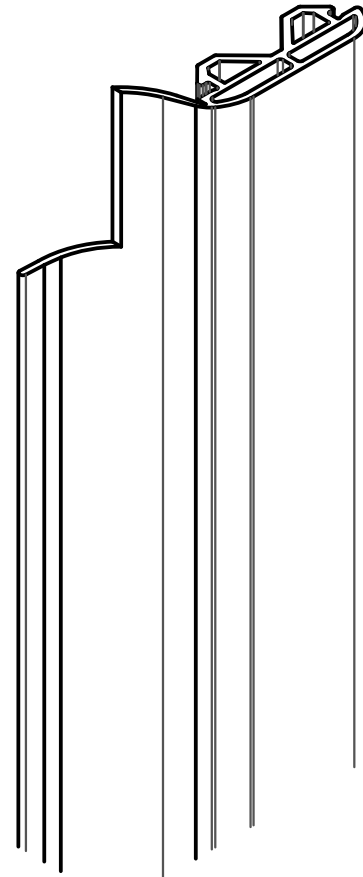
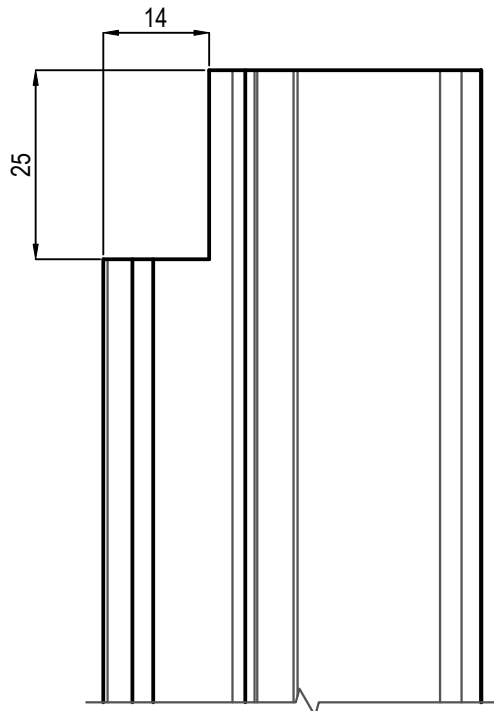

LAV. M30-04

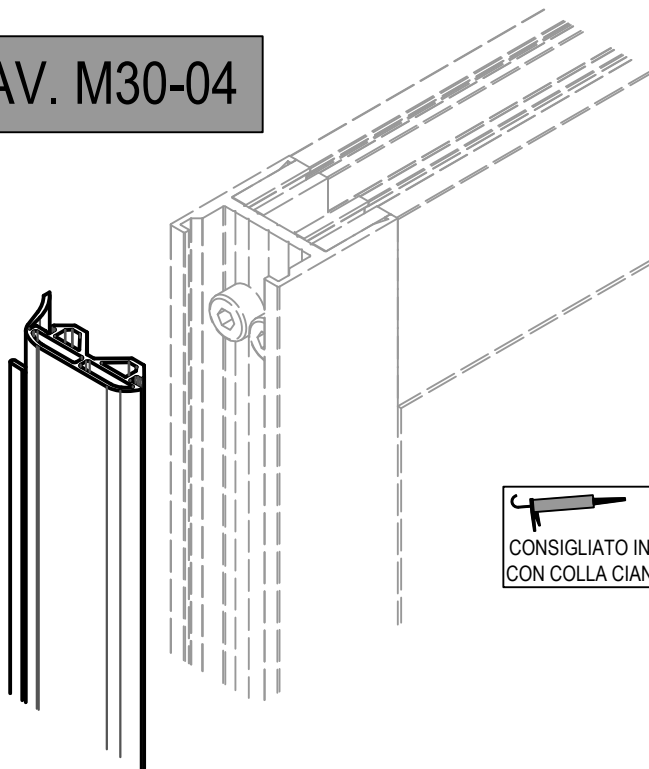

 CONSIGLIATO INCOLLARE
CON COLLA CIANACRILICA

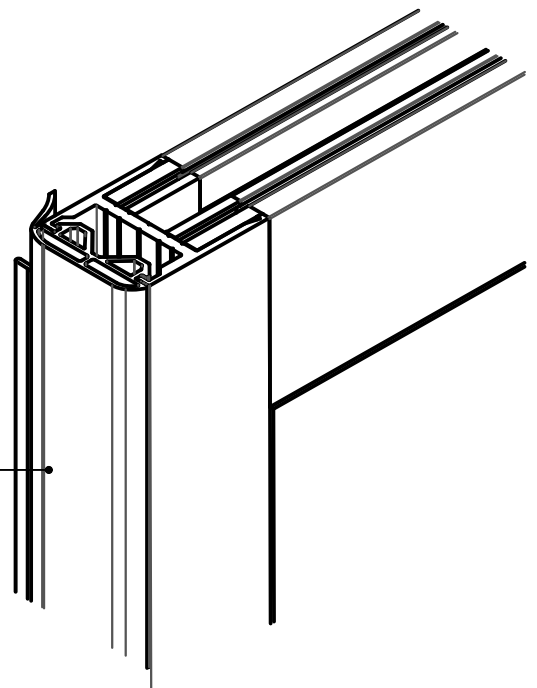

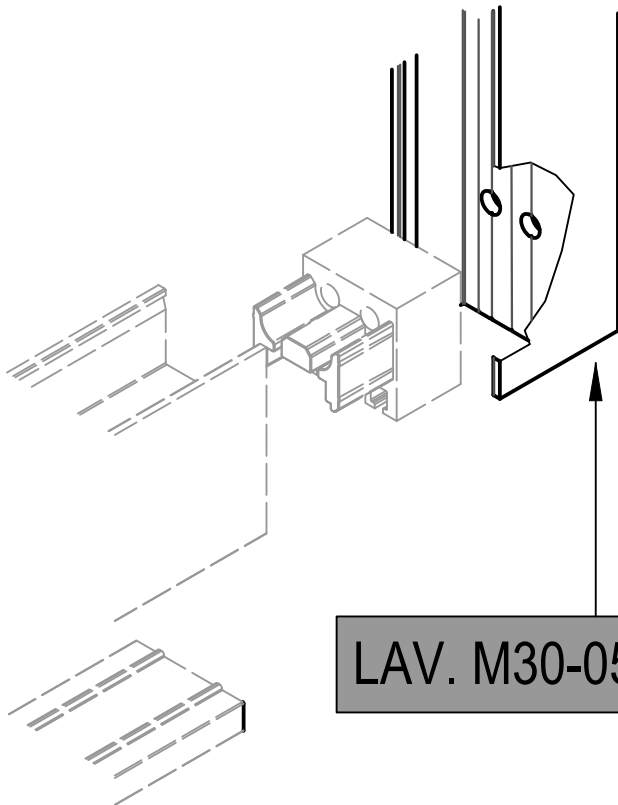
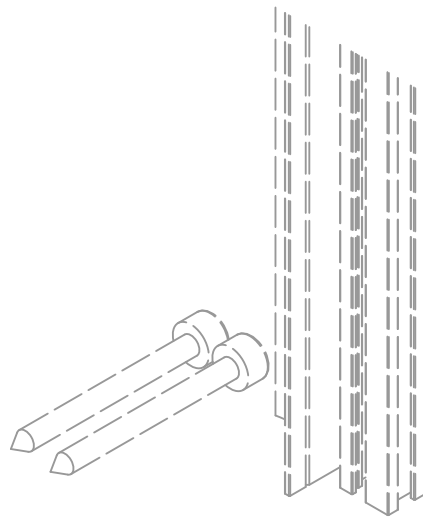
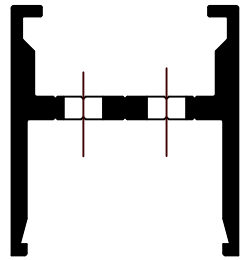
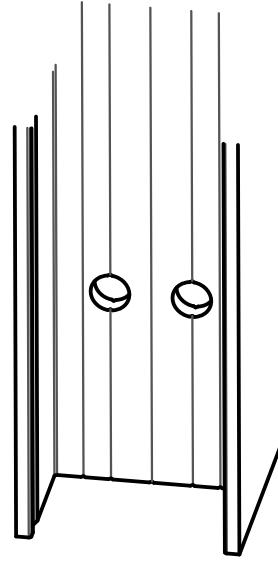
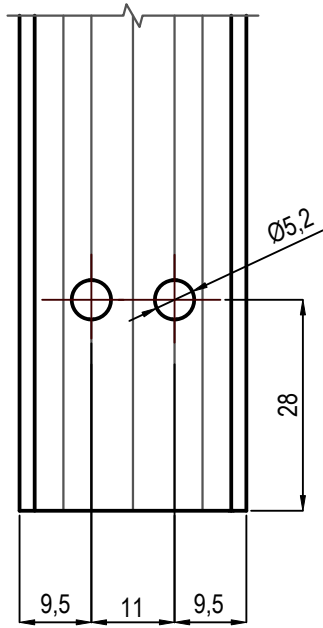

LAV. M30-05

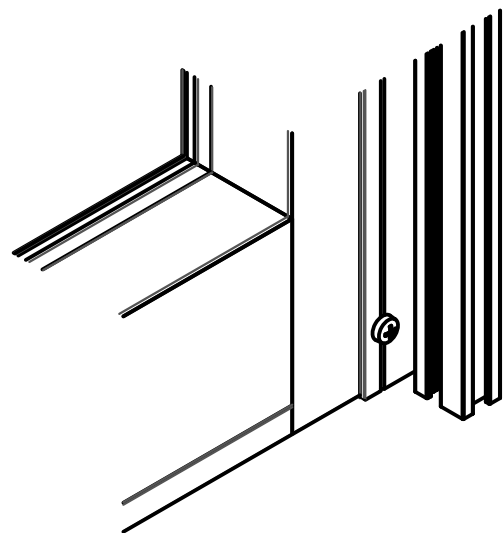

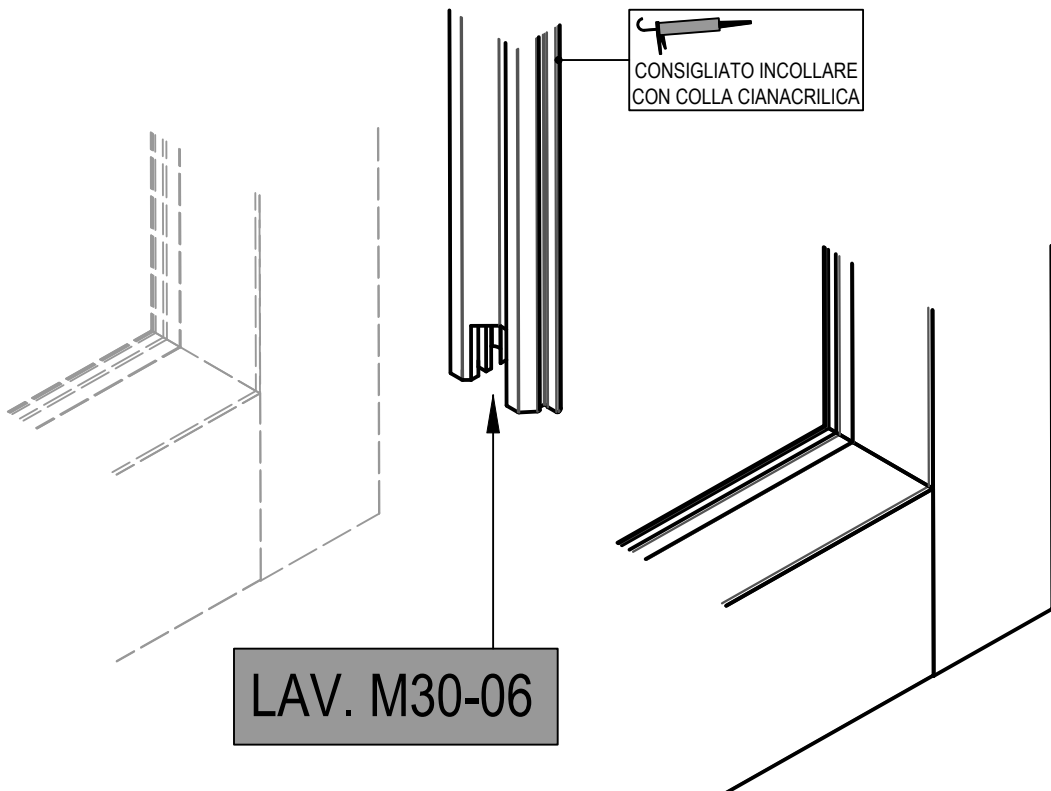
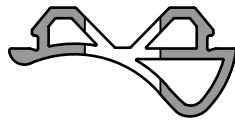
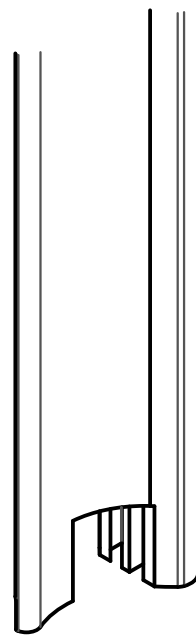
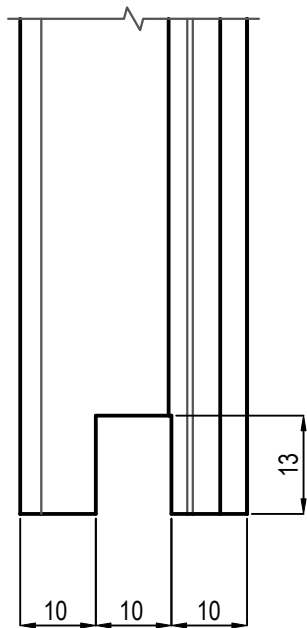

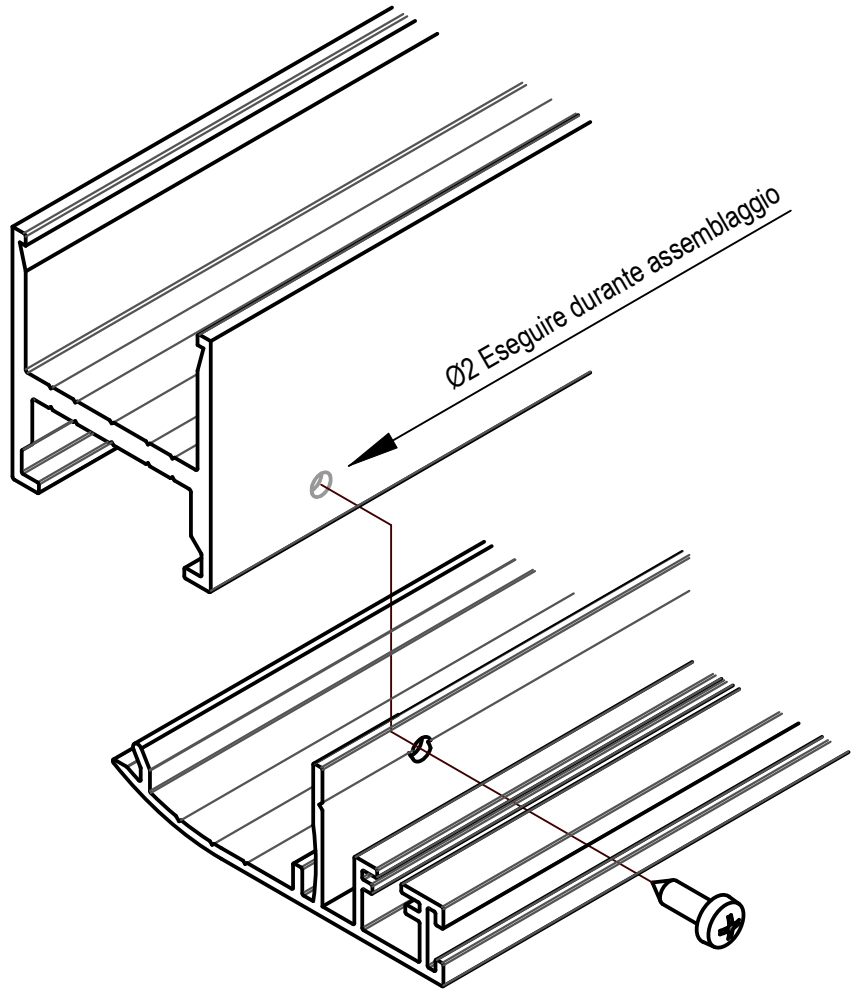
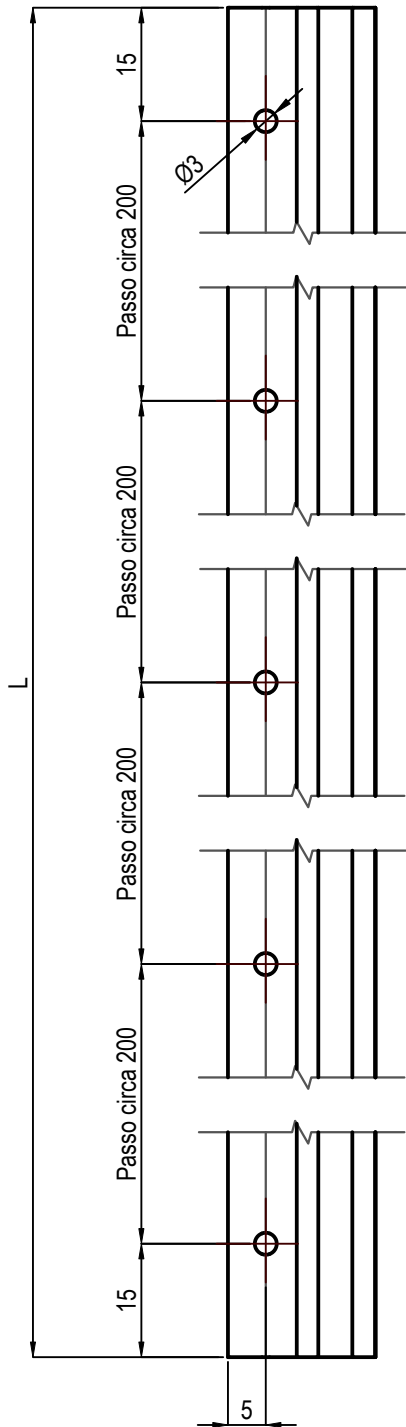

ACCOPIAMENTO TRA LABIRINTO E MONTANTE:

- ANTA SCORREVOLE
- ANTA FISSA
- VANO DI PASSAGGIO

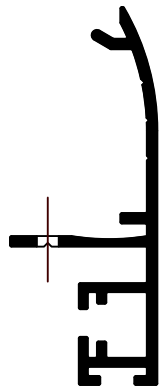



LAV. M30-08 SCALA 1:1

